



**NATIONAL INSTITUTE OF TECHNOLOGY  
TIRUCHIRAPPALLI – 15**

**Office of Dean (Research & Consultancy)**

**Web : [www.nitt.edu](http://www.nitt.edu)**

**Phone : 0431 - 2503030**

**TENDER DOCUMENT**

NITT/F-11/PLAN 2012-13/R&C

Dated: 18.01.2013

Name of the equipment/software & Quantity required :

**OUTDOOR & INDOOR STUDIO EQUIPMENTS, TRANSMISSION EQUIPMENT FOR BROADCASTING AND CONSTRUCTION OF TRANSMISSION TOWER FOR COMMUNITY RADIO STATION: ONE NUMBER**

**EMD** : **Rs. 18,000/-.**  
Cost of the Tender Document : **Rs. 150/-**

Delivery : **45 days**

Address for submission of Tender : The Director,  
National Institute of Technology-  
Tiruchirappalli 620015, Tamil Nadu.  
ATTN to : Dr. B.Venkataramani,  
E-mail : [bvenki@nitt.edu](mailto:bvenki@nitt.edu)

Last Date of submission of Tender : **1.02.2013 up to 3.00 p.m.**  
Date of opening of technical bid : **1.02.2013 at 3.30 p.m.**



**NATIONAL INSTITUTE OF TECHNOLOGY  
TIRUCHIRAPPALLI – 15**

---

**OFFICE OF DEAN (RESEARCH AND CONSULTANCY)**

**Tender Notification No.:** NITT/F-11/PLAN 2012-13/R&C

Dated: 18.1.2013

**NOTICE INVITING TENDER**

The National Institute of Technology, Tiruchirappalli (NITT) is an autonomous body under MHRD, GOI, imparting Technical Education and engaged in Research Activities. It is proposed to procure the following component for the institute academic/research activities.

Sealed Quotations under *two cover system* are invited for the following Equipments and software for Community Radio Station (CRS) in Dean R & C department subject to the following terms and conditions, from the reputed manufacturers or their authorized dealers so as to reach this office on or before scheduled date and time. See section 6 for the details of the proposed Community Radio Station.

OUTDOOR & INDOOR STUDIO EQUIPMENTS, TRANSMISSION EQUIPMENT FOR BROADCASTING AND CONSTRUCTION OF TRANSMISSION TOWER FOR COMMUNITY RADIO STATION : ONE NUMBER

- **The bidders are required to quote for all the items.**
- **The bidders who quote for only some of the items would be disqualified.**
- The bidders may procure the items from different manufacturers but should take the responsibility of demonstrating the compatibility before the submission of the bid.
- **All the bidders are required to give the demo and presentation on the products to be quoted before the submission of the quote. Please contact [muthuc@nitt.edu](mailto:muthuc@nitt.edu) for fixing up the appointment.**
- **A pre-bid meeting is proposed to be held on 22<sup>th</sup> JAN 2013.** Proceedings of the pre-bid meeting would be put in the NITT web site. It is mandatory for the bidders to go through these proceedings and give their quotes taking this into account.
- The bidders should provide a list of institutions (IITs/NITs) where the quoted products are already supplied by them and operational. POs and the contact numbers of the purchaser should be provided. In addition to this, a certificate from the purchasers that these items are performing satisfactorily should be enclosed.
- The bidders should give a declaration that they have quoted for all the items. Only the price bids of the bidders meeting the technical compliance bid would be opened.

**EMD**  
Cost of the Tender Document

**: Rs. 18,000/-.**  
**: Rs. 150/-**

Time for completion of supply after placing purchase order : 45 days  
Tender to be submitted at the following address :

The Director,  
National Institute of Technology- Tiruchirappalli,  
Tiruchirappalli – 620015, Tamilnadu, India.  
ATTN : Dr.B.Venkataramani/Dean R&C  
E-mail : [bvenki@nitt.edu](mailto:bvenki@nitt.edu)

**Last Date of submission of Tender : 1.2.2013 up to 3.00 p.m.**

***Place, Date and time of opening of technical bid* : 1.2.2013 3.30 p.m. Venue: Main Store room**

Bidders or their authorized agents may be present at the time of opening the technical bids

**Note :** The Institute shall not be responsible for any postal delay about non-receipt / non delivery of the bids or due to wrong addressee.

## INSTRUCTIONS TO BIDDERS

**BIDDER'S COPY**

1. This document set contains the following:
  - a) Terms and conditions of the Tender
  - b) Details of the Firm offering this Quote
  - c) Technical Compliance Form
  - c) Quotation form (Price Bid and Technical bid)
  - d) Currency Form (quoted on behalf of the foreign suppliers)
  - d) NIT-T's check list copy
2. The bidder's copy is for your future records. Please fill in and return only NIT-T's copy.
3. The bidder should give details of their technical soundness and provide list of customers of previous supply of similar items to Universities, Institutes or Government Departments/Undertakings/public sectors with contact details. The details of the agency/profile should be furnished along with the copy of all related documents.
4. Read through the terms and conditions given and affix your signature and seal if you find them acceptable. Any deviations may be recorded. Read carefully list of specifications that we have enclosed.
5. Fill in the questionnaire regarding the Firm.
6. The downloaded documents '**Technical Compliance Form**' and '**Quotation Form (Price Bid)**' should be **TYPE WRITTEN USING CAPITAL LETTERS ONLY**. At the time of filling the "**Quotation Form (Price Bid)**" make sure that you have not missed anything. Specify the model number & specification for each item. The form should be filled item-wise. Do not leave blank fields. If you are not quoting for a specific item, you should specify "**NOT QUOTING**".
7. **Do not use** ambiguous terms like "**yes**", "**complied**" or "**available**". Specifically mention the matching specification of the product offered by you. Make sure that you have affixed your signature with date and seal on all the documents.
8. Please send the tenders in a sealed envelope super scribed as "**QUOTATIONS AGAINST TENDER NOTIFICATION NO: NITT/F-11/PLAN 2012-13/R&C COMMUNITY RADIO STATION Date of opening 1.2.2013**" so as to reach "The Registrar, National Institute of Technology, Tiruchirappalli - 620 015, India" on or before **1.2.2013 up to 3.00 p.m. along with a Softcopy of the Technical Compliance form and Quotation Forms in MS-Excel file format in a CD/DVD or USB drive.**
9. For any further clarifications, contact by E-Mail: [bvenki@nitt.edu](mailto:bvenki@nitt.edu) or by written request to "The Registrar, National Institute of Technology, Tiruchirappalli - 620 015, India"
10. Prebid conference will be held on **22<sup>nd</sup> JAN 2013** at 3 PM

**Last Date for receipt of tender at NIT-T : 1.2.2013 up to 3.00 p.m.**

**Opening Date for Tender : 1.2.2013 at 3.30 p.m.**

### **CHECKLIST TO BE FILLED IN BY BIDDER**

List of documents to be enclosed	Completed & Signed
1. Terms and Conditions form	YES / NO
2. Details of the Firm offering this Quote	YES / NO
3. NIT-T's Quotation form (Technical & Price Bid)	YES / NO
4. Currency Form(quoted on behalf of the foreign suppliers)	YES / NO
5. Other technical specifications & pamphlets	YES / NO

- Note:** 1. "Cover" should contain the following:
- a. Form of "**Acceptance of Terms and Conditions**".
  - b. Form of "**Firms details**"
  - c. Pamphlets, if any (in a separate sealed cover)
2. Quotation Form (Technical, Price Bid and Currency Form)

Please retain this page with you for your future reference.

Section 1. IN THE CASE OF TWO BID TENDERS

1.1 *Bids are to be submitted under two cover system.*

1.2 Cover 1:

Cover 1 should contain the following:

- a. *EMD - Earnest Money Deposit (EMD) is to be remitted by way of Demand Draft drawn on any Nationalised bank in India by Demand Draft drawn on any scheduled bank in favour of “The Director, NIT, Trichy” payable at Trichy should be submitted. EMD shall bear no interest. Any bid not accompanying with EMD is liable to be treated as non-responsive and rejected.*
- b. *Technical pamphlets*
- c. *Detailed technical specification*
- d. *The agency should furnish copy of license certificate for manufacture/supply of the item\**
- e. *The agency should furnish Income Tax PAN number & TIN number.\**
- f. *The agency should furnish the last three years balance sheet approved by the CA and the IT clearance certificate.\**
- g. *Warranty period offered for the tendered item to be specified. If the warranty period is not conforming with the schedule of requirements given in section 3 of the document, the bid is liable to be treated as non-responsive and rejected.*
- h. *Duly filled up technical questionnaire, if any*
- i. *Duly filled up deviation schedules to technical specification*
- j. *Copy of supply orders completed during the last three years*
- k. *If the prices are revealed in the cover 1, the offer will be summarily rejected*

1.3 *The cover 1 shall be super scribed as ‘Technical cover’ duly indicating the Tender reference No. and the due date of opening.*

*\* Appropriately pertaining to the country of origin.*

1.3 Cover 2:

Cover 2 should contain the following

*Cover 2 shall contain Price only and shall be super scribed as ‘Price Cover’ duly indicating the Tender Reference No. and the due date of opening.*

*Each Cover shall be sent in a double sealed cover. The inner covers (Cover 1 and Cover 2) should be sealed individually with the Sellers’s distinctive seal and super scribed with the tender reference no. and due date of opening. Both the inner covers shall be placed in a common outer cover which shall also be sealed with seller’s distinctive seal and super scribed with the tender reference no. and due date of opening.*

*Mention “Kind Attention: Dr.B.Venkataramani, and submit at the address given in the Notice Inviting Tender.*

*Cover 1 will be opened on the scheduled date and time mentioned in the tender enquiry.*

*Cover 2 of the technically and commercially suitable offers alone will be opened on a date which will be intimated to the qualified bidders.*

## Section 2. “TERMS AND CONDITIONS FORM”

### IMPORTANT: READ ALL THE FOLLOWING TERMS AND CONDITIONS AND SIGN THE ACCEPTANCE CLAUSE FOLLOWING IT

1. The offers should be addressed to “The Registrar, National Institute of Technology, Tiruchirappalli 620015, India” and should be sent in a sealed envelope super scribed “**QUOTATIONS AGAINST TENDER NOTIFICATION No.: NITT/F-11/PLAN 2012-13/R&C : COMMUNITY RADIO STATION**” so as to reach us **on or before 1.02.2013 up to 3.00 p.m.**
2. Each offer should be sent in a sealed cover with the tender documents. Tenders received through email or FAX will not be considered. **Softcopy of the Technical Compliance form and Quotation Forms should be submitted along with the tender in MS-Excel file format in a CD/DVD or USB drive. However, if there is any dispute between Hard copy and Soft copy, Hard copy will be taken.**
3. The tenders will be opened on **1.02.2013 at 3.30 p.m.** in the presence of the vendors present with authorization letter from the respective companies / firms. Suppliers intending to attend the tender opening should intimate us in advance.
4. Full technical specifications and pamphlets should be sent along with the tenders. **Offers without proper technical specifications will be rejected.**
5. The rate quoted should be on unit basis excluding Taxes. Taxes and other charges should be quoted separately, considering exemptions if any.
6. All offers should indicate the taxes and duties applicable, if any. Additional charges for packing, forwarding, freight, insurance etc., if any, should be clearly mentioned. Clearance at Customs will be arranged by us.
7. NIT-T is paying concessional Customs & Excise duty under Government of India Notification No.51/96 for Central Customs and 10/97 for Central Excise Duty vide Certificate No.TU/V/RG-CDE(183)/2011 dt.10.10.11. Currently the purchaser is paying 5% Basic Customs Duty, 2% Educational Cess on Basic Customs Duty, 1% Higher Education Cess on Educational Cess, and 4% Import Additional Duty.
8. The Institute is not authorized to issue C and D forms of Sales tax certificate.
9. In case the offered items are to be imported, the rates should be quoted in foreign currency on C.I.F. Chennai Airport basis, and it should include the Freight up to Chennai airport and the insurance cover should be up to National Institute of Technology, Tiruchirappalli. NIT-T shall pay Customs duty if any.
10. If the price quoted is in foreign currency and if the order value is more than US\$10,000 then 100% payment will be made through **Letter of Credit (LC) at sight on acceptance.** If the order value is less than US\$10,000, then 100% payment will be through a Telegraphic Transfer (TT). **The bank charges outside India should be borne by the Supplier / Beneficiary. Part shipment not allowed.** If the price quoted is in Indian Rupees, then 100% payment will be made only after installation and commissioning. **No advance payment will be made.**
11. No revision of the price bid will be allowed once the price bids are opened. In case of foreign currency, the agency should mention the % of currency fluctuations they can bear.
12. No increase in price will be allowed after our firm orders are placed.
13. **Payment of excise duty and sales tax / VAT (on ultimate products)** as applicable on the closing date of tender will be to the supplier’s / contractor’s account. Any statutory variation (both plus and minus) in the rate of excise duty/sales tax/VAT after closing date of tender/revised price bid but before the expiry of the contractual delivery / completion period will be to the account of the office.  
The bidder(s) will indicate, in their bid, the amount with exact rate of the Excise and Sales tax/VAT on ultimate finished product, as applicable at tendering stage, separately in the bid. In case the above information subsequently proves wrong, incorrect or misleading (a) this Institute will have no liability to reimburse the excess in the difference in rates of the item under which the duty/tax assessed finally (b) this Institute will have the right to recover the difference in case the rate of duty / tax finally assessed is on the lower side.  
Any increase in excise duty, sales tax / VAT during extended period of the contract / supply order will be to supplier’s / contractor’s account where such extension in delivery of the materials/completion of the project was on the request of supplier / contractor. However, any decrease in excise duty/sales tax/ VAT during extended period of the contract / supply order, will be to the account of this Institute.

14. The warranty period should be clearly mentioned. The maintenance charges (AMC) under different schemes after the expiry of the warranty should also be mentioned.
15. Quote should come from authorized dealer or distributor or reseller for each of the product quoted. An authorization letter should accompany your quote for each product quoted; otherwise it may lead to rejection.
16. The delivery period and other terms should be clearly mentioned.
17. Eligibility: Quotation from registered firms/company's / manufacturer under TNGST/CST / other statutory bodies alone be considered. Any Manufacturer / Supplier / Dealer who has been declared ineligible by World Bank/government of India shall not be eligible to participate in this bid. Any fraudulent practices including concealing of facts at the time of submission of bid and there after shall lead to disqualification. List of beneficiaries especially from Educational Institutions / R & D Institutions should also be enclosed with the quotations.
18. For those instruments Cost exceeding 5,00,000/- the company should have (i) Three similar works, each of value not less than 40% of the estimated cost put to tender, or (ii) Two similar works, each of value not less than 50% of the estimated cost, or (iii) One similar work of value not less than 80% of the estimated cost, all amounts rounded off to a convenient full figure, in the last 7 years ending on the last day of the month previous to the one in which the tenders are invited.
19. Complete user, technical and service documentation, and spare parts catalogue are to be provided along with the supply of the item.
20. The vendors are informed that they should not call us over phone or contact us in person. All clarifications can be obtained through E-Mail/FAX/Post. Vendors shall not make attempts to establish unsolicited and un-authorized contact with us after the opening of the offers and prior to the notification of the award. Any attempt by any vendor to bring to bear extraneous pressures on us shall be sufficient reason to disqualify the vendor.
21. Delay / loss in postal transit or due to other reasons will not be NIT-T's responsibility.
22. We are not responsible for accidental opening of the covers that are not properly super scribed and sealed before the time scheduled for opening.
23. The tender should be made only on the "Technical compliance form" & "Quotation form" which is available in our website; otherwise it shall lead to rejection. The technical compliance form & PRICE BID FORM should be duly filled up (preferably **TYPE WRITTEN IN CAPITAL LETTERS**) and should clearly mention the features offered by the bidder against each specification.
24. Authorized signatory should sign on all the pages. Bids without authorized signatures will be rejected.
25. The manufacturers of the quoted make of the product must be of national / international repute and having ISO /BIS certificate.
26. **Liquidated damages:** If the bidder/supplier, after accepting the Purchase Order, fails to deliver any or all of the Goods within the period specified in the Order, NIT-T shall, without prejudice to its other remedies under the Rules of Purchase, proceed to cancel the order or agree to accept a delayed delivery on the condition of payment of liquidated damages by the bidder / supplier a sum equivalent to 0.50% of the total cost as indicated in the Purchase Order (which will be deemed as agreed price) for each week or part thereof of delay until actual delivery or performance is completed and such penal charges shall be limited to a maximum of 5% of the total cost. Once the maximum is reached NIT-T may proceed on its own to consider the termination / cancellation of the order.
27. **The vendors are informed that they should sign a stamp paper agreement with us, for Warranty, AMC, etc. before placing the final purchase order as per our terms & conditions and 5% of purchase order value in the form of bank guarantee towards performance security. The bank guarantee will be returned to the supplier after the successful completion of supply, installation, and the warranty period.**
28. **The bidders are required to quote for all the items.**
29. **The bidders who quote for only some of the items would be disqualified.**
30. The bidders may procure the items from different manufacturers but should take the responsibility of demonstrating the compatibility before the submission of the bid.
31. Failure to comply with all the terms and conditions mentioned herein would result in the tender being summarily rejected.

32. Vendors are informed that once the companies are shortlisted based on the technical specification, only then the price bids of the firms that meet NIT-T's Technical specification / requirements would be compared.
33. The order will be based on the actual requirement at the time of ordering, optional items may also be ordered based on the actual requirements at the time of ordering. Not quoting for this may result in disqualification.
34. NIT-T reserves the right to modify or alter the specifications after short listing of tenders.
35. NIT-T reserves the right to change the order quantity or split the orders among multiple vendors without assigning any reason(s) whatsoever.
36. NIT-T reserves the right to reject any or all the tenders without assigning any reasons whatsoever.
37. NIT-T reserves the right to purchase decreased number of quantity of the item to be purchased
38. The agencies should submit their rate as per the format given in Section 4 of the Notice Inviting Tender in this cover. All the pages of the bid should be signed affixing the seal. All corrections and overwriting should be initialed.
39. The tender will be acceptable only from the manufacturers or its authorized supplier.
40. The bid shall be in the format of price schedule given in Section 4. The contract form as per format given in section 5 shall be submitted. Incomplete or conditional tender will be rejected.
41. Details of quantity and the specifications are mentioned in Section 3 appended to this Notice Inviting Tender
42. The item to be used is strictly according to the specification and subject to test by the Institute/concerned authorities. It must be delivered and installed in good working condition.
43. The Contractor/Supplier shall have no claim to any payment of compensation or otherwise whatsoever, on account of any profit or advantage which he might have derived from the execution of the work/supply in full but he did not derive in consequence of the foreclosure of the whole or part of the works.
44. In case of dispute, the matter will be subject to Tiruchirappalli, Tamil Nadu Jurisdiction only.

**Release of EMD:** The EMD shall be released after receipt of performance security from successful bidder.

**Validity of bids:** The rate quote should be valid for a minimum of 120 days. No claim for escalation of rate will be considered after opening the Tender.

**Imports:** In case, goods are to be imported, the Indian agent should furnish authorization certificate by the principles abroad for submission of the bid in response to this Notice Inviting Tender.

**Clarification of Tender Document:** A prospective bidder requiring any clarification of the Tender document may communicate to the contact person given in this notice inviting tender.

**Amendment of tender document:** At any time prior to the last date of receipt of bids, Institute may for any reason, whether at its own initiative or in response to a clarification requested by prospective bidder, modify the Tender document by an amendment.

***The Institute may at its own discretion extend the last date for the receipt of bids.***

The bids shall be written in English language and any information printed in other language shall be accompanied by an English translation, in which case for the purpose of interpretation of the bid, the English translation shall govern.

The Institute reserves the right of accepting any bid other than the lowest or even rejecting all the bids without assigning any reasons therefor. The decision of the Institute Purchase Committee is final in all matters of tender and purchase.

The bidder should give the following declaration while submitting the Tender.



## ACCEPTANCE

We accept the above terms and conditions and shall comply with them strictly.

**NAME OF THE VENDOR:**

**ADDRESS :**

### **“DETAILS OF THE FIRM OFFERING THIS QUOTE”**

**(Write or print or type in block letters and please answer all the questions)**

1. Name of the firm?

2. Date of incorporation?

3. Nature of the company - Government / Public / Private Company / Partnership / Proprietorship

4. Specify the number of years in this line of activity by the Company ::

5. Quantity of sales in the last three years for the “.....” (same model that you have quoted)?

2009-2010	2010-2011	2011-2012

6. Turn over in the last three years (Figures should be in Indian Rupees in Lakhs):

2009-2010	2010-2011	2011-2012

7. Provide the postal address, telephone & fax numbers, and email address of the nearest service center.

8. A) Number of service engineers in the above location trained on the product quoted along with their educational qualification, certification and designation (applicable only for instruments) and B) Assured response time for service calls in hours:

A)

B)

9. What would be the delivery period in days from the date we place an official purchase order.

10. Enclose the list of customers to whom you have supplied “.....” during the last 3 years ending 31/03/2012 with full postal address and name of the contact person with phone, FAX numbers, and E-Mail id. Certificate regarding satisfactory performance of the “.....” from the minimum three end users should be furnished.

11. Are you the authorized dealer or distributor or reseller for the products quoted:

12. Have you supplied “.....” to National Institute of Technology, Tiruchirappalli in the last 3 years? If yes, specify the quantity supplied in the last 3 years and last PO reference

13. Was there any elapse or delay in supplying the goods ordered or any service related issue during the warranty period for the products ordered by NIT-T with your firm? If yes, provide details.

14. On Manufacturer’s Side to whom NITT have to contact in case of delayed supply and other issues committed by the authorized dealer / distributor / reseller :

Contact Person Name :	
Address :	
E-mail ID :	Telephone / Cell Phone :

**DECLARATION**

I/we have not tampered/modified the tender forms in any manner. In case, if the same is found to be tampered/modified, I/we understand that my/our tender will be summarily rejected and full Earnest Money Deposit (EMD) will be forfeited and I/we am/are liable to be banned from doing business with NIT, Trichy and /or prosecuted.

**Signature of the Bidder** : .....

**Name and Designation** : .....

**Business Address** : .....  
.....  
.....

**Place :**

**Date :**

**Seal of the Bidder’s Firm**

### SECTION : 3 SCHEDULE OF REQUIREMENTS, SPECIFICATIONS AND ALLIED DETAILS

---

Name of the system to be procured :

OUTDOOR & INDOOR STUDIO EQUIPMENTS, TRANSMISSION EQUIPMENT FOR BROADCASTING  
AND CONSTRUCTION OF TRANSMISSION TOWER FOR COMMUNITY RADIO STATION

Specifications : List attached

Quantity : ONE

Warranty period required : One year or more

Delivery schedule expected after  
release of purchase order : 45 days

EMD (in Rupees) : **Rs.18,000**

Performance Security to be given by  
Successful bidder after release of  
purchase order (in Rupees) : **5% of the total Cost**

**SECTION : 4 PRICE SCHEDULE**

[ To be used by the bidder for submission of the bid ]

---

- 1. Component Name :
  
- 2. Specifications (confirming to Section 3 of Tender document-enclose additional sheets if necessary) :
- 3. Currency and Unit Price(excluding Taxes) :
- 4. Quantity :
  
- 5. Item cost (Sl.No.3 & Sl.No.4) (in Indian Rupee) :
  
- 6. Taxes and other charges :
  - (i) Specify the type of taxes and duties in percentages and also in figures
  - (ii) Specify other charges in figures :
  
- 7. Warranty period (confirming to the Section 3 of Tender document. This should be mentioned in Technical bid also in order to get qualified for Financial bid) :
- 8. Delivery Schedule (confirming to the Section 3 of Tender document) :
- 9. Name and address of the firm for placing purchase order :
  
- 10. Name and address of Indian authorized agent (in case of imports only) :

**Signature of the Bidder** : .....

**Name and Designation** : .....

**Business Address** : .....  
.....  
.....

**Place :**

**Date :**

**Seal of the Bidder's Firm**

**SECTION : 5 CONTRACT FORM**

[ To be provided by the bidder in the business letter head ]

---

1. {Name of the Supplier's Firm) hereby abide to deliver the .....by the delivery schedule mentioned in the Section 3 tender document for supply of the items if the purchase order is awarded.
2. The item will be supplied conforming to the specifications stated in the tender document without any defect and deviations.
3. Warranty will be given for the period mentioned in the tender document and service will be rendered to the satisfaction of NIT, Trichy during this period.

**Signature of the Bidder** : .....

**Name and Designation** : .....

**Business Address** : .....  
.....  
.....

**Place :**

**Date :**

**Seal of the Bidder's Firm**

## SECTION: 6: THE PROPOSED COMMUNITY RADIO STATION

**Community radio** is a radio service offering a third model of radio broadcasting in addition to commercial and public broadcasting. Community stations serve geographic communities and communities of interest. They broadcast content that is popular and relevant to a local, specific audience but is often overlooked by commercial or mass-media broadcasters. Community radio stations are operated, owned, and influenced by the communities they serve. They are generally nonprofit and provide a mechanism for enabling individuals, groups, and communities to tell their own stories, to share experiences and, in a media-rich world, to become creators and contributors of media.

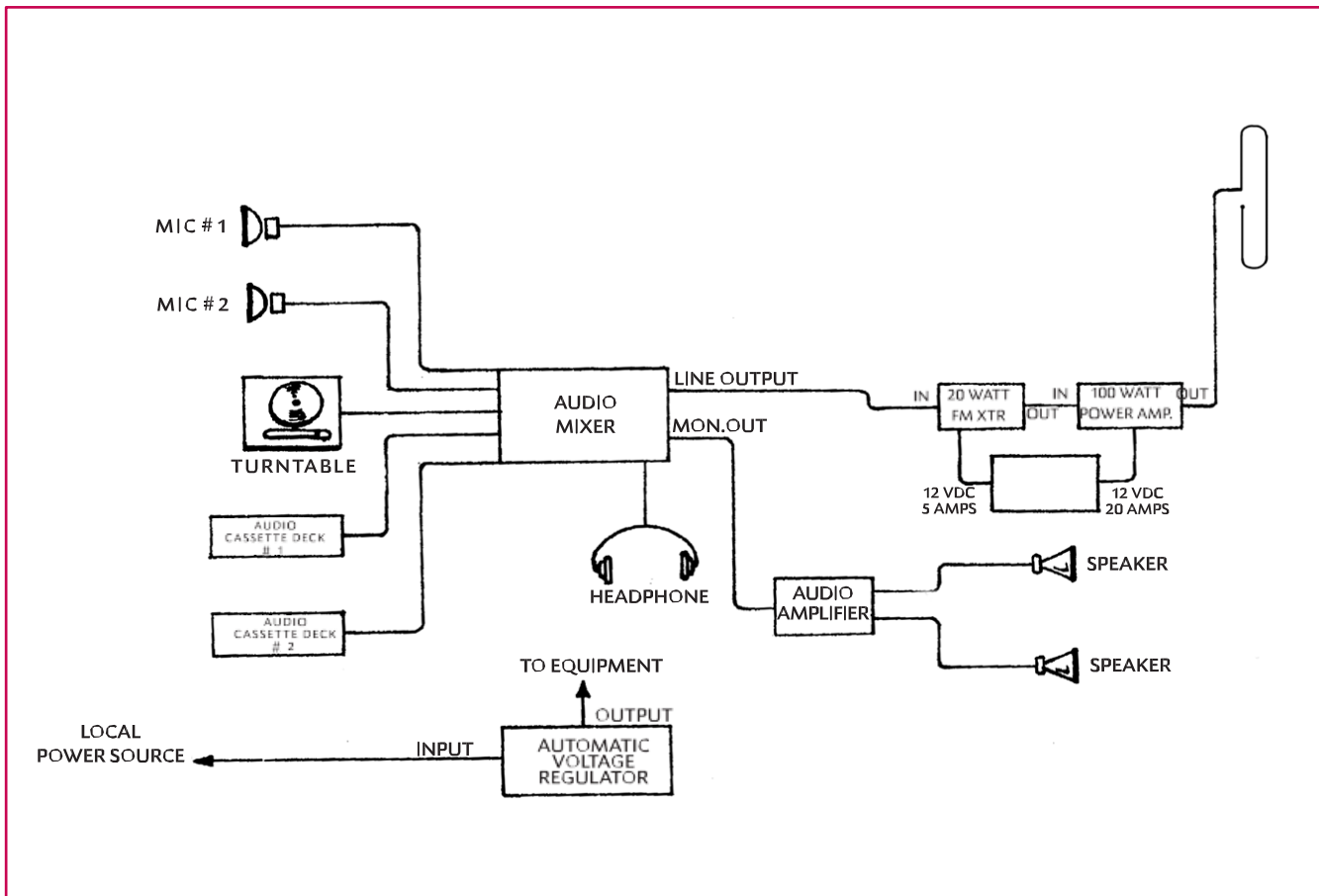

### Specification Details of Community Radio Station.

#### STUDIO EQUIPMENTS.(OUTDOOR&INDOOR)

##### 1.(A) Audio cassette recorder.-

CD- Quality Recording with Linear PCM format, 25hrs Long Recording Time, One-Touch Recording Auto Shut-Off.

##### 1.(B). Digital handheld recorder

Built-In memory – 4 GB or above, PC connectivity, Recording format WAV/MP3/SMA/ AAC,Recording Time : 6 Hrs LPCM – 6Hrs,mp3 8 KBS 1073 Hrs, MP3 48kbs:178 Hrs , MP3 128 KBS:67 Hrs.

1.(C) Lapel microphone :Type : dynamic, Directivity : uni-directional, freq response : 100-12khz, sensitivity : -53dB/mW

1. ( **D** ) **Head phones for Recorders.**Type: Closed, dynamic (supra-aural), Impedance : 24ohms at 1kHz, Freq response : 10 -24 Khz, Driver unit : 102 dB/mW

## **2. Uni-directional microphone**

Type : large-diaphragm condenser, frequency response: 20Hz – 18kHz, sensitivity: 16mV/Pa (-36dBV), Output Impedance : 200 ohms, recommended load impedance: >1,000 ohms

Power requirement: +48V phantom power

## **3. On-air studio microphone**

Type: **Large-diaphragm condenser**, Polar Pattern: **Cardioid**, Frequency Response: **20 Hz – 20 kHz**

Sensitivity: **16 mV/Pa (-36 dBV)**, Output Impedance: **200ohm** Recommended Load Impedance: **>1,000 Ohm**, Power Requirement: **48 V phantom power**

## **6. Mic Pre-amp+ Panthom powered**

1-channel mic/instrument preamp, phantom power, 5Hz-50kHz frequency response

## **7. Stereo audio console – features and specifications**

Low noise, high headroom analog mixer, 4 CH STEREO INPUTS,6 phantom-powered microphone preamps,4 compressors with "one-knob" functionality and control LED for professional vocal and instrumental sound, Effects processor with 16 editable presets including reverb, chorus, flanger, delay, pitch shifter, multi-effects, tap function and storable user parameter settings, Built-in stereo USB audio Interface to connect directly to a computer; includes audio recording, editing.

### **Specifications**

**Total # Of Inputs:** 16 Inputs, **Mic/Line Inputs:** 6 x XLR Microphone Inputs, **Stereo Line Inputs:** 4 x 1/4" TRS Left & Right Paired Inputs, **Phantom Power:** +48V Phantom, **Frequency Response:** Mic Input to Main Output: <10 Hz - 90 kHz (+0 dB / -1 dB),

**8. Studio monitor:** 2-way active studio monitors with 2 x 10W amplification and Bass/Treble controls for Desktop Audio, Multimedia, and Keyboard workstation applications

## **9. Studio Talk back System:**

Should be professional talkback communication between studio recording room (voice over booth) to operator, **Frequency Response:** 10Hz - 25kHz, +/- 0.5dB, **Power:** 20mA @ 200 -230Vac

## **10. Headphones – monitoring:**

Type: Closed, dynamic (supra-aural), Driver Unit: 30mm, dome type (CCAW Voice Coil), Frequency Response: 10-24,000 Hz, Impedance: 24ohms at 1kHz.

## **12.PC BASED DIGITAL WORK STATION:**

**The system should be supplied with the following configuration, specification and features**

- Intel® Core i3 @3.0GHZ or above ,
- 2GB of RAM;
- 1280x800 display- lcd Monitor – 17”
- 1 TB - HDD AND external HDD 500 GB for Storage
- MOUSE/KEYBOARD.
- DVD-RW
- UPS : 120 minutes
- Operating system: Microsoft® Windows® XP with Service Pack 3 or Windows 7 with. Recording and editing software with pro-tools.
- Sound Interface card compatible with following specification

frequency response:	22Hz-22kHz, -0.2,-0.4dB @48kHz
---------------------	--------------------------------

	22Hz-40kHz, -0.2,-0.7db @96kHz
dynamic range:	101.5dB (D/A) (A-weighted)
	99.6dB (A/D) (A-weighted)
THD:	< 0.002% (A/D and D/A)
size/weight:	5-1/8" x 7/8" x 5-3/8"; 0.25 lbs.
8 x 8 analog I/O	
2 mic preamps or line inputs	
S/PDIF digital I/O (coaxial) with 2-channel PCM	
SCMS copy protection control	
digital I/O supports surround-encoded AC-3 and DTS pass-through	
1 x 1 MIDI I/O	

### **15.High signal cables for all installation:**

RG – 58 U – CO-AXIAL CABLE TO BE USED.

### **16..RCA,XLR(both male & Female) phone jacks both mono & stereo –**

MX MAKE – OR – QUALITY ONE

### **17. Telephone Patch - 2port**

The Patch is a little box that connects between the base of an analog telephone and the wall jack. can continue to talk on the phone and get access to audio on both sides of the call.

- Trunk Port Compatibility: Two-wire loop start or ground start
- Frequency Response: 200 – 8000 Hz,  $\pm 1$  dB
- Input/Output Impedance: 600 ohms, nominal
- Power Requirements: 230v ac or 24V DC @ 150mA

### **19. ON AIR Lamp**

ON AIR indicator – LED OR LAMP TYPE.

### **20. TRANSMISSION EQUIPMENT(for Broadcast)**

#### **FM STEREO TRANSMITTER – 50 WATTS SPECIFICATION**

**Frequency** - 87.5 - 108 MHz,

**Power** : 5-50(50W) Watt adjustable, Encoder : stereo

#### **BROADCASTING ANTENNA SPECIFICATION:**



Gain	>4.5 dBi w.r.t. Half Wave Dipole
Input frequency	87.5-108 MHz, Band II Wide Band
VSWR	Less than 1.3
Input impedance	50 ohm
Lightening Protection	All metal parts to be DC grounded
Feed power handling	300W
Polarization	Vertical
Maximum Wind Speed	200 Km/Hour

## **21. Feeder - RG-213 CABLE**

## **22. PC Based Radio Automation**

### **Radio Automation Software should have the following Features:**

**The Player** is the central component of software With it should Launch and edit playlists. Schedule various events For advertising, specify volume increase. Automatic volume leveling, crossfading and silence trimming. It should Use the 'playlist within playlist' to create sophisticated multi-hour audio programming. It should Easily create random playlists, Include Internet streams (HTTP, MMS and FTP) in the playlists. And Apply a wide range of audio effects including echo, reverb, flanger, tempo, pitch. It should Improve the quality of any given audio by 12-band equalizer. And It should Support Internet streaming.

**The Playlist Generator** It should create playlists. Automatically generate playlists for a given duration. Generates playlists quickly using and reusing playlist templates. Supports multiple generation options. Create playlists with rotations. Create playlists with jingles. Create playlists with hour markers and commercials.

**The Music Database** should organizes audio assets, Automatic indexing supports quick searches., Filter and sort to work with just records want. Automatically tracks usage statistics. Tag any audio asset, regardless of format, Tag mutple audio assets. Add comments to any audio asset.

**Audio Logger** : scheduler – automatic recording start/stop of recording in specified hours encoding into mp3, ogg or other codec on the fly, without intermediate WAV recording directly from playback device ,records can be split into parts low CPU load keeping history of records automatic deletion of old records flexible configuration options full Windows Vista and 7 support, 32 and 64 bit

The above featured Radio Automation software should supplied with the following system configuration and the OS: System Processor : CORE i3 @ 3.0 GHz or above, RAM - 2 GB , HDD-500GB, MONITOR-LCD17” KEYBOARD, MOUSE and OS-WINDOWS -7

## **23 TOWER WITH CIVIL WORK**

<b>Height</b>	30 feet
<b>Section at Top</b>	Triangle
<b>Material Tubes</b>	GI PIPE , Indian standard <b>IS :1239</b> , 1 inch pipe
<b>Construction</b>	6 sections x 5 FT plus base or 3 section x 10 ft plus base
<b>Base Mount</b>	Installed in 0.5 to 1 cubic METER of concrete with base plate.

# COMPLIANCE OF THE SPECIFICATIONS OF COMMUNITY RADIO STATION.

## STUDIO EQUIPMENTS.(OUTDOOR&INDOOR)

Description	NIT-T's Specifications	Company Specifications	Reason for Difference
1. Audio cassette recorder	CD- Quality Recording with Linear PCM format, Long recording time, One touch Recording Auto Shut-Off		
2. Digital handheld recorder	Built-In memory, PC connectivity, Recording format :WAV/MP3/SMA/AAC, Recording Time : 6 Hrs LPCM – 6Hrs, MP3 8 KBS 1073 Hrs, MP3 48kbs:178 Hrs , MP3 128 KBS:67 Hrs.		
3. Lapel microphone	Type : dynamic, Directivity : uni-directional, Freq response : 100-12kHz, Sensitivity : -53dB/mW		
4. Head phones for recorders	Type: Closed, dynamic (supra-aural), Impedance : 24ohms at 1kHz, Freq response : 10 -24 kHz, Driver unit : 102 dB/mW		
5. Uni-directional microphone	Type:large-diaphragm condenser, Frequency response: 20Hz – 18kHz, Sensitivity: 16mV/Pa (-36dBV), Output Impedance: 200 Ω, Recommended load impedance:> 1kΩ power requirement : +48V phantom power		
6. On-air studio microphone	Type: Large-diaphragm condenser, Polar Pattern: Cardioid, Frequency Response: 20 Hz – 20 kHz Sensitivity: 16 mV/Pa (-36 dBV), Output Impedance: 200Ω Recommended Load Impedance: >1kΩ Power Requirement: 48 V phantom power		
7. Mic pre-amp+ pantom powered	1-channel mic/instrument preamp, phantom power, Frequency response :5Hz-50kHz		
8. Stereo audio console	Low noise, high headroom analog mixer, 4 ch stereo inputs Total # of inputs: 16 Inputs, Mic/Line Inputs: 6 x XLR Microphone Inputs, Stereo Line Inputs: 4 x 1/4" TRS Left & Right Paired Inputs, Phantom Power: +48V Phantom, Frequency Response: Mic Input to Main Output:<10 Hz - 90 kHz (+0 dB / -1 dB),		
9. Studio monitor	2-way active studio monitors with 2 x 10W amplification and Bass/Treble controls for Desktop Audio, Multimedia, and Keyboard workstation applications		
10. Studio talk back system	Frequency Response : 10Hz - 25kHz, +/- 0.5dB, Power: 20mA @ 200 -230Vac		
11. Headphones – monitoring:	Type: Closed, dynamic (supra-aural), Driver Unit: 30mm, Dome type (CCAW Voice Coil), Frequency Response: 10-24,000 Hz, Impedance: 24Ω at 1kHz.		

12. PC based digital work station:	Intel® Core i7@3.0GHz or above 4GB of RAM 1280x800 display- LCD Monitor – 17” 1 TB - HDD and external HDD 500 GB for Storage Mouse/keyboard. DVD-RW UPS : 30 minutes Operating system : Microsoft® Windows® XP with Service Pack 3 or Windows 7 with Recording and editing software with pro-tools.		
13. Sound interface card compatible	Frequency response: 2Hz-22kHz, -0.2,-0.4dB @48kHz 22Hz-40kHz, -0.2,-0.7db @96kHz dynamic range:101.5dB (D/A) (A-weighted) 99.6dB (A/D) (A-weighted) THD: < 0.002% (A/D and D/A) size/weight: 5-1/8” x 7/8” x 5-3/8”; 0.25 lbs 8 x 8 analog I/O 2 mic preamps or line inputs S/PDIF digital I/O (coaxial) with 2-channel PCM SCMS copy protection control digital I/O supports surround-encoded AC-3 and DTS pass-through 1 x 1 MIDI I/O		
14. High signal cables for all installation:	RG – 58 U – co-axial cable to be used.		
15. RCA, XLR (both male & Female) phone jacks both mono & stereo	MX make – or – quality one		
16. Telephone patch – 2 port	Trunk Port Compatibility: Two-wire loop start or ground start Freq Response: 200 – 8000 Hz, ±1 dB Input/Output Impedance: 600 Ω, nominal Power Requirements: 230V AC or 24V DC @ 150mA		
17. On air lamp	On air indicator – LED OR LAMP TYPE.		
<b>TRANSMISSION EQUIPMENT(for Broadcast)</b>			
18. FM stereo transmitter	Frequency - 87.5 - 108 MHz, Power : 5-50(50W) Watt adjustable, Encoder : stereo		
19. Broadcasting antenna	Gain >4.5 dBi w.r.t. Half Wave Dipole Input frequency 87.5-108 MHz, Band II Wide Band VSWR: < 1.3 Input impedance: 50 Ω Lightning Protection: All metal parts to be DC grounded Feed power handling: 300W Polarization: Vertical Maximum wind speed: 200 Km/Hour		
20. Feeder	RG-213 cable		

21. PC based radio automation	Radio Automation Software should be with the features given in Annexure 1		
TOWER WITH CIVIL WORK			
22. Height	30 feet		
23. Section at Top	Triangle		
24. Material Tubes	GI PIPE , Indian standard IS :1239 1” pipe		
25. Construction	6 sections x 5 FT plus base or 3 section x 10 ft plus base		
26. Base Mount	Installed in 0.5 to 1 cubic meter of concrete with base plate.		