



NATIONAL INSTITUTE OF TECHNOLOGY
TIRUCHIRAPPALLI - 620 015, TAMIL NADU
WEB site: www.nitt.edu

Notice Inviting Tender for Layout Design, Supply, Installation and Commissioning of Electrical Machine work stations for the Electrical Machines Laboratory and Power Electronics Laboratory at National Institute of Technology, Tiruchirappalli-15

Department of Electrical and Electronics Engineering

BID SYNOPSIS	
Tender Reference Number and Date	NITT/F.NO/ UG-MOD 001, 002/ PLAN 2014-15/EEE Dated 27.8.2014
Brief Description of the Equipment/ System/ Project to be Designed, Supplied, Installed and Commissioned on turnkey basis	Electrical Machine work stations for the Electrical Machines Laboratory (7 numbers) and Power Electronics Laboratory (5 Numbers).
Type of Tender	Two Bid System
Cost of Tender Document including 5% VAT (Non- refundable)	Rs.1000/ (Rupees One Thousand only) payable through DD drawn in favour of The Director, NIT, Tiruchirappalli, Tamil nadu Payable at Tiruchirappalli-15
Our web site address for downloading the Tender document	The tender document should be downloaded from our website www.nitt.edu
Earnest Money Deposit (Refundable)	Rs. 6 lakh (Rupees Six Lakh) payable through Demand Draft or through Bank Guarantee drawn in favour of The Director, NIT, Tiruchirappalli, Tamil nadu.
Date of Pre bid Meeting	Monday 8 th September 2014 at 2.30 p.m. (Venue: A 13 Hall, Administrative Building, NIT, Tiruchirappalli-15).
Last Date and Time for receipt of tender	Monday 22 nd September 2014 upto 3 P.M
Mode of submission of Tender	By Speed Post/ Register Post/ Courier or through Hand delivery at the Postal Section of the Main Office, NITT.
Due Date, time & venue for Opening of Tender	Monday 22 nd September 2014, 3.30 P.M, A 13 Hall
Date and time of opening of Price bids	After evaluation of technical bids, the date, time and place of opening of the Price bid will be intimated to technically qualified bidders.
Address for submission of Tender	The Director, National Institute of Technology, Tiruchirappalli-15, Tamil Nadu, India Kind Attention: Dr.S.Senthil Kumar, Assistant Professor, EEE Department, National Institute of Technology, Tiruchirappalli-15, Tamil nadu
Procedure for submission of Bid	Envelope 1 : EMD and Cost of Tender document Envelope 2 : Technical Bid Envelope 3: Price bid Envelope 4: Larger size Outer Envelope (Wrapper)
Contact person for Technical Queries	Dr. S. Senthil Kumar, Assistant Professor, EEE Department, National Institute of Technology, Tiruchirappalli-15, Tamil nadu Phone Number: 0431- 250 3261 E Mail ID : skumar@nitt.edu

Notice inviting Tender

Sir/s, National Institute of Technology, Tiruchirappalli, Tamil Nadu (**herein after referred to as NITT**), a premier Technical Educational Institution of National Importance, hereby invites sealed tenders from reputed Original Equipment Manufacturers or their authorized agents/ dealers/ distributors/channel partners for Layout Design, Supply, Installation and Commissioning of Electrical Machine work stations for the Electrical Machines Laboratory (7 Numbers) and Power Electronics Laboratory (5 Numbers). The detailed technical specifications of the Equipment/ System/ Project/ Job proposed to be executed through this Open Tender is given in **Chapter Number 7** of this tender document (please refer to page number 11-26 of this tender document)

INDEX FOR THE TENDER DOCUMENT

Chapter Number	Heading/ Name of the Chapter	Page Reference
Chapter 1	Tendering Process	3-4
Chapter 2	Pre bid Meeting	4
Chapter 3	Pre-qualification criteria	4-5
Chapter 4	Special Instructions to the Bidders	5-6
Chapter 5	Terms and conditions for Purchase	6-8
Chapter 6	Additional Terms and conditions for imported items	8-10
Chapter 7	Technical Specifications	11-26
Chapter 8	Format for submission of TECHNICAL BID	27-29
	<u>Annexures to Chapter 8: Format for submission of Technical Bid</u>	
	Annexure 1 : Technical Specification Compliance Sheet	29
	Annexure 2 : Format for Manufacturers Authorization Letter to Agent	30-31
	Annexure 3 : Types of items/ goods/ equipment/ system/ project supplied, installed and commissioned during the preceding 3 years	31
	Annexure 4 : Details of SIMILAR works/ system/ equipment/goods/ project supplied, installed and commissioned during the preceding 3 years to the IITs, NITs, Central/ State Universities or any other Higher Educational Institution under Government of India	32
	Annexure 5 : Price Reasonability Statement	32
	Annexure 6 : Affidavit regarding black listing/ non blacklisting from taking part in Government Tenders	33
	Annexure 7 : Certificate of Guarantee/ Warranty	33-34
	Annexure 8 : Certificate and Declaration by the Bidders	35
	Annexure 9 : Checklist and Important dates for the bidders	36-37
Chapter 9	Format for submission of PRICE BID in respect of Indigenous Purchase	38
Chapter 10	Format for submission of PRICE BID in respect of Foreign Purchase i.e., Imports	39

CHAPTER 1: TENDERING PROCESS

1. The tender document and terms and conditions can be downloaded from our website www.nitt.edu.
2. Through two separate Demand Drafts, the bidder is required to furnish Rupees 6 lakh (Rupees six lakh only) towards Earnest Money Deposit and Rupees 1000 (One thousand only) towards Cost of Tender Document. Instead of through Demand Draft, the Earnest Money Deposit (EMD) can be submitted in the form of Bank Guarantee also.
3. **Without EMD and Cost of Tender Document, the technical bid will not be opened and the tender will be rejected summarily.**
4. **The sealed tender should be submitted on or before Monday 22nd September 2014 upto 3.00 P.M., through Registered Post or Speed Post or hand delivery and addressed to the Director, National Institute of Technology, Thuvakkudi, Tiruchirappalli-15, Tamil Nadu, India. [Kind Attention: Dr.S.Senthil Kumar, Assistant Professor, EEE Department, National Institute of Technology, Tiruchirappalli-15]**
5. At the first stage, the envelope containing EMD amount and Cost of Tender document will be opened and at the second stage the envelope containing Technical Bid will be opened on Monday 22nd September 2014 3.30 P.M at in the presence of the bidders or their authorized representatives, who choose to be present at the time of opening.
6. At the time of opening of Tender, the names of those who have submitted their offers along with the details of their remittance of EMD and Cost of Tender Document will only be read out and no other information/ details whatsoever will be shared at this stage.
7. If in any case, unscheduled holiday occurs on prescribed closing/ opening date, the next working day shall be the prescribed date of closing/ opening.
8. Subsequent to evaluation of technical bids, price bids of the technically acceptable offers will be opened for further evaluation and ranking for award of the contract/ purchase order. The date of price bid opening will be intimated to the bidders of technically qualified bids.
9. The bidders are advised to go through the tender documents and understand the terms and conditions specified therein before submitting the tender.
10. **The Tender document consisting of Technical Bid (along with all NINE annexures to the technical bid) and Price Bid should be submitted in the Prescribed Format only.**
11. The bidders are not allowed to make addition or alteration in the Technical or Price Bid.
12. Each and every page of the submitted bid shall carry the page numbers.
13. All pages of the tender document should be signed by the person or persons duly authorized to sign, on behalf of the bidder along with the official stamp of the bidder.
14. No paper / page shall be detached and No addition or alternation should be made in the tender document. Conditional tender, late and delayed tender will not be accepted/ considered.
15. Printed condition at the back of the letter or bid from the tenderer will be ignored. If it is desired to apply any particular condition to tender, the same must be clearly brought out in the body of the bid/ tender itself.
16. The NITT shall not be responsible for any postal delay in receipt of the offer. Tender should be properly sealed.
17. The NITT will not be responsible for pre mature opening of the tenders.
18. The offers submitted by telex/ telegram/ fax/ E-mail etc. shall not be accepted and will be summarily rejected.
19. Offers should be clearly written or typed without any cutting or over writing. All cutting / over writing must be initialed and stamped.
20. Bidders must confirm the acceptance of all the terms and conditions of the tender.
21. Making misleading or false representation in the bid document will lead to disqualification of the bidder resulting

in forfeiture of EMD amount.

22. Any non-acceptance or deviations from the terms and conditions must be CLEARLY mentioned. However, bidder must note that any conditional offer or any deviation from the terms and conditions of this tender may render the bids liable for rejection.
23. **Earnest Money Deposit (EMD):** The Tenders/ Bids must be accompanied by Earnest Money Deposit. The bidders who are registered with National Small Industries Corporation (NSIC) are exempted from EMD and cost of tender document. However, for claiming this exemption, the bidders MUST furnish an attested copy of the exemption certificate indicating Date of registration, validity period of the registration, whether registered for items for which tender has been floated. The EMDs of all the unsuccessful bidders will be returned to them at the earliest after issue of purchase order. The EMD of successful bidder shall be returned on receipt of Performance Bank Guarantee. No interest will be payable by the NITT on the EMD amount.

CHAPTER 2: PRE BID MEETING

It is proposed to conduct a Pre - Bid meeting on **Monday 8th September 2014 at 2.30 P.M** (Venue: A 13 Hall, Administrative Building, NIT, Tiruchirappalli-15. The purpose of the meeting is to clarify the requirements and to answer the questions of the prospective bidders on technical bid and commercial terms and conditions of this tender. Also, during **1.9.2014 to 6.9.2014** the prospective bidders may visit the laboratory premises in the Department of Electrical and Electronics Engineering, at National Institute of Technology, Tiruchirappalli where the electrical machine work stations are proposed to be installed. The prospective bidders may inspect the premises with the prior appointment with Dr.S.Senthil Kumar.

View above, prospective bidders are advised to submit their doubts/ questions/ clarifications, if any, through Mail, (Mail ID: **skumar@nitt.edu**) before the date of Pre bid meeting. Further, on the date of the meeting, the questions should be given in writing. Any modification of the bidding documents which may become necessary as a result of the Pre bid meeting shall be made known to all the prospective bidders by the Purchase Committee through a notification of amendment in the website of the NITT.

As regards ultimate technical and commercial specifications, the decision of the Director / NITT, shall be final and conclusive. No clarifications will be entertained beyond the date of pre bid meeting. No extension of time will be given for submission of tender on any account, beyond the last date for submission of tender.

Corrigendum if any, with respect to this tender will be hosted only in the website <http://www.nitt.edu>. Please visit the website regularly for any updates.

CHAPTER 3: PRE QUALIFICATION CRITERIA

1. The Bidder must be an Original Equipment Manufacturer (OEM) or his Authorized Dealer/ Authorized Distributor/ Authorized Stockist/ Channel Partner having a Direct Purchase and Support agreement with the OEM. In case, if the Bidder is a Dealer/ Distributor, a valid LETTER OF AUTHORIZATION from the Original Equipment Manufacturer for Dealership, Distributorship or for Channel Partnership must be attached in original, with technical bid, without which the offer will not be considered.

2. The Average Annual Turnover of the Bidder during the last three years ending 31st March 2014 should be at least Rs.90 lakh (Rupees ninety lakh). A Printed copy of the Annual Accounts duly audited and certified by the Chartered Accountants must be enclosed with the technical bid. Year in which no turnover is shown would also be considered for working out the average turnover.

3. Experience of having successfully completed similar works during last 7 years ending 31st August 2014 should be any of the following:

- a. Three similar completed works costing not less than Rupees 1.20 crore each
- b. Two Similar completed works costing not less than Rupees 1.50 crore each
- c. One similar completed work costing not less than Rupees 2.40 crore

Definition of Similar work:

- a) Layout Design, Supply, Installation, Commissioning and Successful Operation of Electrical Machine work stations for the Electrical Machines Laboratory or Power Electronics Laboratory. This means the entire work of Layout Design, Supply, and Installation of various electrical machines with associated wiring and instrumentation, testing, commissioning and successful operation on a turn-key basis **and**
 - b) The above work should have been carried out in renowned educational institutions such as Indian Institute/s of Technology, National Institute/s of Technology, Central/ State Universities or in any of the Higher Technical educational institutions functioning under the control of Ministry of Human Resources Development.
4. Performance Certification: The bidders' performance for each work completed in the last three years should be certified by the responsible official from the concerned Educational Institution for whom similar job/ work/ system/ project was executed by the bidder.

The above mentioned basic eligibility conditions are broad guidelines for pre-qualification and the Director, NITT hereby reserves the right to relax/ alter/ modify / add, any or all the conditions.

CHAPTER 4: SPECIAL INSTRUCTIONS TO THE BIDDERS

Procedure for sealing and marking of bids: The Tender / Bid Cover shall contain the following:

- a) **FIRST** envelope should contain the Earnest Money Deposit and Cost of Tender Document. The envelope should be sealed and super scribed as "EMD COVER"
- b) **SECOND** envelope should contain the Technical Bid along with enclosures desired in the Tender document. This envelope should be sealed and super scribed as "TECHNICAL BID" Cover.
- c) **THIRD** envelope should contain the Price Bid. This envelope should be sealed and super scribed as "PRICE BID" Cover.
- d) All the above mentioned THREE SEPARATE ENVELOPS are to be sealed and kept in one single Larger size outer envelope (**FOURTH** envelope) which should also be sealed and super scribed.

e) Each of the **FOUR ENVELOPS** shall be super scribed with following details:

Tender reference Number	for supply of
Due date of tender	and time
Name of the Department inviting this tender.....	
Name and Complete address of the Bidder	

- f) If all the **THREE** inner envelops and the **ONE** outer envelope (i.e., larger envelope) are not sealed and marked as instructed, NITT will assume no responsibility for the misplacement or premature opening of any of the envelope. An envelope opened prematurely will be rejected.
- g) There shall **NOT** be any price indication in the technical bid. If for any reason, it is found that the technical bid reveals the price bid related details in any manner whatsoever, or, the price bid is enclosed in the envelope super scribed, “Technical Bid”, the bid document will be summarily rejected in the first instance itself. Any offer containing both the Technical bid and Price bids in the same envelop will also be out rightly rejected.

CHAPTER 5: TERMS AND CONDITIONS FOR PURCHASE

Technical Specifications are basic essence of this work/ Project/ Job/ Equipment. It must be ensured that the offers are strictly as per our specifications. At the same time it must also be kept in mind that merely copying our specifications in their quotation shall not make the bidder eligible for consideration. The specifications mentioned in the quotation have to be supported with the printed catalogue/ leaflet / standard technical literature/ brochure for each of the item offered. Model quoted / tendered specifications should invariably be highlighted in the leaflet/literature for our easy reference.

Rates: Rates for Indigenous items must be on **DOOR DELIVERY** Basis, which should be **inclusive** of all taxes, duties and levies. The break up may be given as given below: Basic Price (+) Central Excise Duty (+) VAT/ CST, if any (+) Freight and Transit Insurance Charge, if any (+) Installation and Commissioning Charge, if any (+) Any other charges, if any Grand Total on Door Delivery Basis at NIT, Tiruchirappalli (i.e., F.O.R Destination basis)

- The price quoted shall be firm and fixed. The rate should be quoted both in figures and words.
- Where the work/ equipment/ project is comprising of several items/ sub units / components, the rate should be clearly indicated for each of the item/ sub unit/ component.
- Prices of each of the additional, optional accessories, should be indicated **SEPARATELY**.
- The spare parts/ wear & tear, consumables, if any required for trouble free operation of equipment/ project shall be quoted separately giving full nomenclature, rate, quantity and shelf life of each item.
- All applicable taxes, duties etc., should be clearly and separately mentioned in the Price bid.

Validity of the Offer: The offer should be valid for 120 days.

Genuine Pricing: The bidder has to ensure that the quoted price for NITT is not more than the Price Offered to any other customer in India to whom this particular work/ equipment/ system/ project has been supplied, installed and commissioned, particularly to Indian Institute of Technology, National Institute of Technology, State/ Central Universities, Defense Organizations, Research Establishments or any other Government Institutions. For this purpose the vendor has to furnish a price reasonability certificate in the Format Prescribed to the Technical Bid. Name and contact details of the premier educational institutions where the quoted item/ equipment/ project/ system has

been supplied/ installed and commissioned during the last three years should be attached with the Format for Technical Bid.

EXEMPTION FROM EXCISE DUTY AND CUSTOMS DUTY: The NITT is exempted from paying Central Excise Duty and eligible for Concessional Rate of Customs Duty. Wherever required/ applicable, we shall provide exemption certificate issued by Government of India to enable the vendor to clear the goods without payment of Excise Duty or Clearance of Imports at Concessional Rate of Customs Duty. Present rate of Customs Duty is 5% Basic Customs Duty, 2% Educational Cess on Basic Customs Duty, 1% Higher Education Cess on Education Cess. In addition, wherever applicable Special Additional Duty (SAD) will be paid at the rate of 4%.

Sales Tax: In respect of items purchased for Research and Development purposes, TN VAT or Central Sales Tax should be charged at concessional rates as applicable to educational and research institutions running without profit motive, for which necessary End User Certificate, will be issued by NITT at the time of retirement of document. Further, the successful bidder may furnish the following certificate on the Invoice/ bill: "Certified that the goods on which Sales Tax has been charged have not been exempted under the Central Sales Tax (CST) or the State Sales Tax Act or the rules made thereunder and the amount charged on account of sales tax on these goods are not more than what is payable under the provisions of relevant act/ rules made thereunder."

Service Tax: NITT is exempted from Service Tax in respect of Educational Auxiliary Services. (Please refer to Serial number 9 of Government Notification No. 25/2012- ST dated 2012).

PAYMENT TERMS FOR INDIGENOUS PURCHASES:

- No advance payment will be made. No part payment will be made.
- 50% Payment will be made on Layout Design and supply of the project/ system/ equipment and remaining 50% on testing, installation and commissioning and successful operation.
- For Imports payment, Please refer additional conditions at Chapter Number 6.
- NITT shall not be responsible for any loss, damages and shortage during transit. Payment shall be made for materials received in good condition only.
- Payment will be generally through Electronics Transfer of Funds (EFT) system for which the successful bidder has to furnish the following information: Name of the bank with branch where the accounts exist, Bank Account Number, IFSC Code etc.,

Warranty/ Guarantee:

- ❖ The project/ equipment/ system must be warranted against all manufacturing defects for a period of FIVE YEARS from the date of satisfactory Supply, installation and commissioning.
- ❖ The Warranty Coverage should be on Comprehensive terms i.e., BOTH FOR LABOUR AS WELL AS REPLACEMENT OF SPARE PARTS.
- ❖ In case, a part thereof or the whole equipment is found defective during the period of warranty, the same will have to be rectified / replaced on FREE OF COST basis without lapse of time.
- ❖ The project/ equipment/ system shall be unused, brand new, calibrated and supplied along with the calibration certificate.

PERFORMANCE BANK GUARANTEE (PBG):

- ✓ As Performance Security, the successful bidder shall furnish an unconditional Performance Bank Guarantee (PBG) from a Nationalized Bank or Scheduled commercial bank for an amount equal to 10% of the Purchase order value and it should be kept valid for a period of 60 days beyond the completion of the Standard/ Free

Warranty Period of Five years. The PBG, shall be furnished in the Format specified by NITT.

Execution/ Delivery Schedule: Unless otherwise specified, the project/ system/ job shall be executed at NITT within 150 days from the date of receipt of the Purchase Order or as stipulated in the Purchase Order. All aspects of safe delivery shall be exclusive responsibility of the vendor. Part supply/ delivery is normally not acceptable, but may be allowed on genuine cases, on written request only. The acceptance of the equipment shall be based on (a) successful demonstration of the system/ project (ii) satisfactory working of the system/ project/ equipment after successful commissioning as tested by the purchase committee of the NITT.

Liquidated Damages for delayed supply: If the successful bidder fails to perform the supply or supply, installation and commissioning, within the stipulated time then penalty at the rate of 1% per week subject to a maximum of 10% of the order value will be levied and deducted.

Purchasers' Right: Notwithstanding anything specified in this tender document, The Director, NITT, in his sole discretion, unconditionally and without assigning any reasons, reserve the rights (a) To accept or reject the lowest tender or any other tender or all the tenders, at any time prior to the award of the tender, without incurring any liability to the affected bidder or bidders (b) To accept any tender in full or in part (c) To reject the tender offer not confirming to the tender terms (d) To give purchase preference to Public Sector Undertaking wherever applicable as per Govt. Policy/ Guidelines.

No enquiry shall be made by the bidder(s) during the course of evaluation of the tender till final decision is conveyed to the successful bidder. However, the Purchase Committee or its authorized representative can make any enquiry/seek clarification from the bidders. In such a situation, the bidder shall extend full co-operation. Any effort by the bidder to influence the scrutiny / evaluation committee of NITT or any of its members in the processing of tenders or award decisions may result in the rejection of the tender.

Black listing: The bidder should not have been blacklisted or debarred from participating in tenders in any State/ Central Government agencies or autonomous bodies or Universities / Educational Institutions.

Supervision of Erection and Commissioning: Successful bidder shall depute concerned specialist, for supervision of Erection and Commissioning of the entire set-up to be carried out as and when necessary. It is specifically instructed that the bidders will supply all the operating and service manuals and circuit diagrams along with the equipment.

Arbitration: Dispute, if any, arising out of the supply of the Items shall be settled by Arbitration by SOLE Arbitrator to be nominated by the Director, NITT as per the provisions of Indian Arbitration Act 1996. The Place of Arbitration shall be Tiruchirappalli, Tamil Nadu. The decision of the Arbitrator shall be final and binding on both the parties.

Applicable law, Dispute and Jurisdiction: Legal disputes if any, in connection with this tender/ procurement/ contract, are subject to exclusive jurisdiction of Competent Court in Tiruchirappalli, (Tamil Nadu, India) ONLY.

Force Majeure: Any delay due to Force Majeure will not be attributable to the Vendor.

CHAPTER 6: ADDITIONAL TERMS FOR IMPORTED ITEMS

In the case of foreign purchase, the following terms and conditions will be applicable, besides the above mentioned terms and conditions:

1. Rates: Quoted rates should be separately in FCA/ FOB/ CIF Chennai terms and charges to be stated in the following break up: (a) Ex-works value (b) Documentation and handling charges, if any (c) Forwarding and Packing charges if any (d) Total FOB/ FCA Value (e) For CIF Chennai, Insurance, Freight and (f) Total CIF Price up to Chennai

Airport/ Sea Port.

2. The Price bid in respect of imported items should be submitted in the Format prescribed at **Chapter 10** of this tender document.

3. **Order Acknowledgement:** Please note that Letter of Credit will not be opened unless and until, Letter of Acknowledgement in original is received at NIT, Tiruchirappalli, directly from the Principal (even in the case of firms having subsidiary office in India). The Indian Agents are therefore advised to submit quotation after consultation with their respective Foreign Principal.

4. PAYMENT TERMS IN RESPECT OF IMPORTS THROUGH FOREIGN PURCHASE ORDER:

4 (a) 50% of the Purchase Order Value shall be paid through Irrevocable Letter of Credit on shipment of the consignment and remaining 50% of the CIF value shall be released after satisfactory installation and commissioning of the equipment and furnishing of 10% Performance Bank Guarantee. A condition to this effect will be incorporated in the Letter of Credit.

4 (b): NO advance payment: In respect of Foreign Purchase Order value more than 10,000 USD no advance payment will be made, even if the foreign vendor is willing to furnish bank guarantee for an amount equivalent to the advance amount.

5. Bank Charges: For letter of Credit, all the bank charges within India will be borne by NITT and all the bank charges outside India will have to borne by the Supplier. LC amendment charges due to mistake on the part of the supplier, if any, will have to borne by the Supplier.

6. Warranty/ Guarantee: FIVE YEARS from the date of installation and successful commissioning of the system/ project/ job.

7. Performance Bank Guarantee: The Foreign Supplier/ Indian Agent shall arrange to furnish a Performance Bank Guarantee (PBG) from a nationalized or Scheduled Commercial Bank Operating in India for an amount equal to 10% of the Purchase Order Value and the PBG shall be kept valid for a period of 60 days beyond the completion of the Warranty Period.

8. Delivery/ Execution Schedule: Supply, installation and Commissioning of the project/ system/ equipment will have to be made maximum within 120 days from the date of receipt of purchase order or otherwise within the Delivery Schedule stipulated in the Purchase order, whichever is earlier. The equipment shall be packed for air / ship in a manner suitable for export in accordance with internationally accepted export practice and in such a manner so as to protect it from damage and deterioration in transit. The supplier will be held responsible for all damages due to improper packing.

9. Mode of dispatch: Ordered item / equipment/ system should be dispatched by Air / Sea on CIF basis on receipt of Letter of Credit. The vendors are required to submit the details of the consignment such as weight of the consignment, dimension of the packing and number of packets etc., at the time of shipment. The import is permissible by Government of India under Export & Import Policy. Partial shipment is not permitted. However, Transshipment is permitted.

10. Insurance: Insurance shall be arranged by the Foreign Supplier for an amount equal to 110% of the value of goods from Warehouse to Chennai Air/ Sea Port.

11. Customs Duty: The Institute is partially exempted from payment of Customs Duty. The Present rate of customs duty is 5% Basic Customs Duty, 2% Educational Cess on Basic Customs Duty, 1% Higher Education Cess on Education Cess. We will provide customs duty exemption certificate for customs clearance. **The bidder must invariably indicate classification number under customs tariff for the items to be imported.**

12. Import Documents to be submitted to the Banker: Though all expenses for Customs Clearing including customs duty will be met by NITT, the foreign vendor and the Indian Agent shall have to render assistance in clearing the Customs. Copies of the following documents should be submitted to the Banker: (a) Complete set of Clean Bill of Lading / Air Way Bill / Air or Surface Parcel Receipt, showing that the goods have been shipped and Freight pre-paid (b) Duly Signed Supplier's Commercial Invoice (strictly in compliance with the terms and conditions of the Purchase Order) indicating description / specification of the goods, quantity, unit price, total value, date of delivery etc.,). This should be bank attested. (c) Packing List / Post Parcel Wrapper wherever applicable, (d) **Country of origin certificate obtained from the chamber of commerce**, (e) Insurance Certificate, (f) Guarantee or Warranty Certificate, (g) Technical Write up, literature, catalogue, brochure etc., (h) OEM Test Certificate shall be sent to the NITT Faculty who is initiating this tender / purchase proposal, immediately after the shipment so enable the NITT to arrange for the Customs Clearance. (i) Supplier shall be held responsible for any Demurrage / Wharfage paid at Customs due to non-receipt of original documents in time for clearance and they have to refund such amount.

13. HIGH SEA SALES: HIGH SEA SALES PROPOSALS NEED NOT BE SUBMITTED.

14. Agency Commission: If no agency commission needs to be paid, the vendor is requested to mention "NIL" agency commission.

15. Indigenous items: The items which can/ are to be procured indigenously shall have to be listed separately.

16. Installation and Technical Support: The equipment shall be installed at our NIT, Tiruchirappalli site by the service engineers deputed by the firm with your instruments, accessories, tools and tackles, deploying appropriate manpower with technical and maintenance support.

17. Genuine Pricing and Liquidated damages: The terms and conditions applicable to Indigenous purchases regarding Validity of the quote, Liquidated damages for delayed supply, Genuine pricing etc., are also applicable to Foreign Purchase (i.e., Imports) also.

18. After sales service: In case of imported items, foreign manufacturing firms should indicate facilities available for after sales service, detailed address and contact number of their local representative in India without which their offers will liable to be ignored.

CHAPTER-7 TECHNICAL SPECIFICATIONS

1) Specifications for Electrical machine workstations to the Electrical Machines Laboratory and Power Electronics Laboratory

It is planned to set up Electrical machine workstations for Electrical Machines Laboratory and Power Electronics Laboratory of National Institute of Technology, Tiruchirappalli.

1.1) Design of layout of electrical machine workstations (scope of vendor)

a) For electrical machines laboratory: The space (35m x 6.7m) tentatively earmarked in the institute shall be utilized by the vendor for mounting the **7** new installations in an optimal manner to suit the specifications in the tender document (in section 1.2a of this chapter).

b) For Power Electronics laboratory: The space (11.6m x 6.7m) tentatively earmarked in the institute shall be utilised by the vendor for mounting the **5** new installations in an optimal manner to suit the specifications in the tender document (in section 1.2b of this chapter).

The final design of layout of electrical machine workstations (both 1.1a and 1.1b) shall have the approval of NITT prior to preparation of concrete beds by NITT.

1.2) Description of one electrical machine workstation:

a) For electrical machines laboratory:

The composition of a single electrical machine workstation for Electrical Machines Laboratory is shown in Fig. 1. Each electrical machine workstation should contain two **Composite Machine Benches (CMB)** known as CMB-A and CMB-B, each of which in turn has two parts, termed part1 and part2. The Composite Machine Bench consists of electrical machines, a variable output isolation transformer, a load bank, associated instrumentation facilities, a laptop/computer (not in the scope of supply of vendor), a wooden worktable, relevant switchgear and connection wires. The grouping of the machines as part1 and part2 are detailed in Fig.1 to Fig.5.

Seven electrical machine workstations should be set up in the electrical machines laboratory.

b) For Power Electronics Laboratory:

The composition of a single electrical machine workstation for Power Electronics Laboratory is shown in Fig.6. The arrangement of the electrical machine workstation in this case is similar to that of Electrical Machines Laboratory (specified in 1.2a). The electrical machine workstation in the Power Electronics Laboratory should have all the elements as in Electrical Machine laboratory (specified in 1.2a). In addition, it should contain two AC drives and two DC Drives.

Five electrical machine workstations should be set up in the power electronics laboratory.

1.3) Arrangement of the CMBs in one electrical machine workstation (applicable to both 1.2a and 1.2b)

Each electrical machine workstation should accommodate:

- i. Composite Machine Bench A: Part1 consists of the machine layout shown in Fig. 2.
- ii. Composite Machine Bench A: Part2 consists of two single phase transformers as shown in Fig.3
- iii. Composite Machine Bench B: Part1 consists of the machine layout shown in Fig. 4
- iv. Composite Machine Bench B: Part2 consists of a single phase induction machine coupled with a DC machine shown in Fig. 5.

This arrangement is common for both Electrical Machines laboratory (1.2a) and Power Electronics laboratory (1.2b) as shown in Fig.1 and Fig.6. The complete instrumentation at the electrical machine workstation shall be placed alongside, with adequate clearance to facilitate the experimental activities of the students. The wiring for various power supply connections to the machines in each electrical machines work station shall be designed and implemented by the vendor. The allocated space for each electrical machine workstation is 3000mmx1650mm approximately for both sections 1.2a and 1.2b.

1.4) Quantity

- A. Electrical Machines Laboratory : **7 Electrical Machine work stations**
- B. Power Electronics Laboratory : **5 Electrical Machine work stations**

2) Technical specifications

2.1) Part1 of Composite Machine Bench A and B

Part1 of each composite machine bench consists of one three-phase induction machine, two identical dc machines and one synchronous machine. The machines shall be laid out in one single row and coupled in the manner shown in Fig.2 and Fig.4.

The three-phase induction machine is placed at one end. It is coupled through a love-joy coupling to a dc machine having shaft extension on both sides. The other side of the dc machine is coupled to another dc machine having double side shaft extension through an electromagnetic clutch. This second dc machine is further coupled to a synchronous machine through a love-joy coupling. The two dc machines must be identical units.

The electromagnetic clutch should be powered from the workbench. All these machines are to be mounted on a common frame as depicted in Fig. 2 and Fig. 4. This frame is to be fixed to the concrete bed. The overall assembly is to be restricted to the dimensions shown in Fig. 2 and Fig. 4. The machine set should also have two slotted discs mounted on the shaft for speed sensing. The positions are shown in Fig. 2 and Fig. 4. A suitable pickup (if optical sensor is used casing must be IP 54, not shown in Fig. 2 and Fig. 4) shall be used to sense the speed from the slotted disc. This should be used to provide speed indication on the workbench. A panel meter shall be used on the workbench with a switch to select the input from anyone of the three pickups (two in part1 of CMB-A/CMB-B, one in part2 of CMB-B). Both pulse and dc outputs must be provided.

The concrete bed and machine assembly should also have a facility to lock the rotor of the induction machine while doing tests. The maximum speed which the set must withstand is 2500 rpm.

2.2) Part2 of Composite Machine Bench A

It consists of two single phase transformers mounted on a common frame as shown in Fig.3.

2.3) Part2 of Composite Machine Bench B

The single phase induction machine coupled with DC machine is shown in Fig.5. The coupled set would also have slotted disc mounted on the shaft for speed sensing. A suitable pickup (if optical sensor is used casing must be IP 54, not shown in Fig.5) shall be used to sense the speed from the slotted disc. This would be used to provide speed indication on the workbench.

3) Specifications of Individual Machines / components

3.1) THREE-PHASE INDUCTION MACHINE

QUANTITY : 24 UNITS (7x2+5x2)*

The induction machine is specified as follows.

Power Rating	:	1 kW
Stator Voltage	:	415V \pm 10%
Rotor	:	Squirrel cage, with bar skew of one rotor slot width
Frequency	:	50Hz \pm 5%
Poles	:	4, slip to be in range (4-6)%
Power factor	:	Greater than or equal to 0.8 @ full Load
Efficiency	:	Greater than or equal to 80% @ full load
Insulation	:	Class F with temperature rise limited to Class B
Protection	:	IP55
Enclosure	:	TEFC
Duty Class	:	S1
Standards for testing	:	Applicable IS
Termination	:	Terminal box, all six terminals of stator winding (3- phase and two ends for each) need to be brought out.

Provision is to be made to operate the machine as star/delta on the stator.

Efficiency shall be as given above. Deviation shall not be accepted w.r.to IS guidelines

*7 electrical machine workstations for Electrical Machines Laboratory and 5 electrical machine workstations for Power Electronics Laboratory.

3.2) SINGLE-PHASE INDUCTION MACHINE

QUANTITY : 12 UNITS (7 x 1+ 5 x 1)

The induction machine is specified as follows.

Power Rating	:	1 kW
Stator Voltage	:	230 \pm 10% V
Rotor	:	Squirrel cage, with bar skew of one rotor slot width
Frequency	:	50 \pm 5% Hz
Poles	:	4, slip to be in range (4-6)%
Power factor	:	Greater than or equal to 0.8(@ full Load
Efficiency	:	Greater than or equal to 80% @ full load

Starting Type	:	Capacitor Start Capacitor Run
Insulation	:	Class F with temperature rise limited to Class B
Protection	:	IP55
Enclosure	:	TEFC
Duty Class	:	S1
Standards for testing	:	Applicable IS
Termination	:	Terminal box, terminals for Auxiliary winding and the Capacitor to be brought out.

DC machine is to be set up as the load for the single phase induction machine.
Efficiency shall be as given above. Deviation shall not be accepted w.r.to IS guidelines

3.3) DC MACHINE

QUANTITY : 60 UNITS (7x5+5x5)

The two DC Machines in the set are to be identical. Their specifications are as follows.

Power Rating	:	1.1kW
Speed(rpm)	:	1500
Type	:	Shunt/Separately Excited
Armature Voltage	:	220V
Field voltage	:	220V
Maximum Field Current	:	not more than 0.8A
Poles	:	4 pole, laminated
Full load Efficiency	:	Equal to or better than 70%
Insulation	:	Class F with temperature rise limited to Class B
Protection	:	IP23
Enclosure	:	TEFC
Standards	:	Applicable IS
No load voltage ripple factor	:	lesser than 1% at rated speed
Duty class	:	S1
Termination	:	Terminal box, all 4 winding terminals (2 field + 2 armature) brought out

Efficiency shall be as given above. Deviation shall not be accepted w.r.to IS guidelines

3.4) SYNCHRONOUS MACHINE :

QUANTITY : 24 UNITS (7x2+5x2)

The specifications of the synchronous machine are as follows.

Power Rating	:	1.5 kVA, 0.8 pf Lag
Type	:	Salient Pole/ cylindrical rotor*.
Field excitation	:	220 V, through slip rings
No. of poles	:	4
Frequency	:	50±5%Hz
Stator voltage	:	415±10% V, 3 phase
Field current	:	0.8 A at 0.8 pf lag
Max field current	:	1 A
Efficiency	:	Equal to or better than 80%

Short Circuit current	:	Greater than 3 times full load current
Duty Class	:	S1
Damper winding	:	Required
Insulation	:	Class F with temperature rise limited to Class B
Protection	:	IP23
Enclosure	:	TEFC
Termination	:	Terminal box, six stator winding terminals & two field winding terminals

Stator phase voltage waveform -3rd harmonic : < 3% of fundamental THD: < than 4%, slot harmonics <0.1% of fundamental

*The vendor shall supply 12 cylindrical rotor machines and 12 salient pole rotor machines. Efficiency shall be as given above. Deviation shall not be accepted w.r.to IS guidelines.

3.5) THREE-PHASE TRANSFORMER

QUANTITY : 24 UNITS (7x2+5x2)

The transformer should be of variable output (autotransformer-like) isolation type. The secondary shall be wound over the primary with suitable insulation between them. The secondary output shall be tapped by means of a brush arm moving on it. Brushes for the three phase windings shall be made to move in tandem by means of a common arm. The general overall size shall not exceed 600 mm (height) X 300 mm (width) X 300 mm (depth). The mechanical arrangement shall be such that the rotating shaft (at the user end) shall be horizontal.

Power Rating	:	1.5 kVA
Type	:	Dry type, isolation auto- transformer with continuously variable output by means of tapping.
Input Voltage	:	3 phase, 4 wire, 415±10% V
Output Voltage	:	3 phase, 4 wire, 0-440V
Frequency	:	50±5%Hz
Insulation	:	Class F with temperature rise limited to Class B
Winding Connections	:	Star/Star
Terminal	:	Input: RYBN terminals marked Output: RYBN terminals marked
Termination	:	Banana Socket, 10A rated
Temperature rise	:	Within Class B limits
Cooling	:	Natural Air Cooled
Protection	:	IP23
Enclosure	:	TEFC

3.6) SINGLE-PHASE TRANSFORMER

QUANTITY :24 UNITS (7x2 + 5x2)

The single-phase transformer is specified as follows.

Power Rating	:	1.5 kVA
Type	:	Dry type.
Primary Voltage	:	230±10%V
Secondary Voltage	:	50%:86%:100% of nominal secondary voltage
Frequency	:	50±5%Hz
Protection	:	IP23
Enclosure	:	TEFC
Termination	:	Banana Socket, 10A rated
Temperature rise	:	Within Class B limits
Cooling	:	Natural Air Cooled

3.7) ELECTROMAGNETIC CLUTCH

QUANTITY :24 UNITS (7x2 + 5x2)

Type	:	Dry type
Speed	:	2500 rpm (max)
Torque	:	20Nm
DC voltage	:	24V
Engaging Current	:	2A
Cooling	:	Natural Air Cooled

3.8) SLOTTED DISC

QUANTITY :60 UNITS (7x5 + 5x5)

Thickness	:	2mm
No of Slots	:	120
Material	:	MS, powder coated type
Colour	:	Same as machine body
Outer Diameter	:	95mm

3.9) LOAD BOX

QUANTITY :24 UNITS (7x2 + 5x2)

The load box is a three phase resistor bank. The resistance in each phase is variable by a switch, ganged together for simultaneous variation in each phase. The general overall size shall not exceed 600 mm (height) X 300 mm (width) X 300 mm (depth).

Element Type	:	Non Inductively Wound resistors
Phase	:	3 Phases
Frequency	:	50±5%Hz
Power Rating	:	1.5kW
Voltage	:	415±10%V
No of steps in each phase	:	Five
Terminations	:	Banana socket, 10A rated

Cooling : Forced air with fan drawing ambient air from outside

The load box shall have six terminations, two for each phase. The wiring must be suitably heat resistant and done such that between each pair of terminals, the effective resistance must vary in five steps by the action of the switch. The maximum power dissipated by the box when connected in three phase star manner shall be 1.5 kW. The ganged switch shall also have one position such that no resistance is connected in any phase (open circuit). The ganged switch shall be guaranteed for at least 16000 operations.

The terminals and the selector switch of the load box shall be brought on to the terminal area of the workbench.

3.10) INSTRUMENTATION PANELS

There shall be two instrumentation panels per electrical machine workstation, one for CMB A, CMB B as shown in Fig.1 and Fig 6. Each of these panels shall have provision to make the following types of measurements — voltage (TRMS), current (TRMS), three phase power and single phase power. The bench shall also have a speed indication in rpm (derived from the pickups on the machine set). There shall be a provision to allocate a wooden worktable (850mmX1500mm) along with the instrumentation panel to carry out the experimentation. The worktable top should be made with waterproof, termite resistant plywood with a laminated smooth surface. The frame may be of steel for the table. The design of the table shall be such that the 3-phase transformers, load boxes and drive cabinet can be easily accommodated in the table. There shall also be a provision of a draw-out so as to house the computer keyboard and mouse. The structure of the worktable is shown in Fig.7.

A storage area should be provided on the top of the worktable as shown in Fig.7 which should be made of the same material as mentioned above.

A. Voltage and Current Measurements

QUANTITY : 24x5 Units for voltage and 24x5 Units for current

The vendor shall provide current measurement through a Hall Effect sensor. The sensor used shall be LEM LA-25NP or equivalent subjected to the approval of purchase committee. Each sensor shall be equipped with suitable signal conditioning circuitry to provide an output limited to ± 10 V. Five such current sensors shall be housed in one powder coated metal box. This box shall have terminals that provide input to the hall sensors and output terminals to take output from the hall sensors. The outputs from all the five hall current sensors shall have a common ground. The box shall also have a power supply input terminal block accepting suitable power supply to be used for the output side circuitry of the hall sensors. This box is referred to as the 'HC box'.

The vendor shall provide voltage measurement through a Hall Effect sensor. The sensor used shall be LEM LV25-800 or equivalent subjected to the approval of purchase committee. Each sensor shall be equipped with suitable signal conditioning circuitry to provide an output limited to ± 10 V. Five such voltage sensors shall be housed in one powder coated metal box. This box shall have terminals that provide input to the hall sensors and output terminals to take output from the hall sensors. The outputs from all the five hall voltage sensors shall have a common ground. The box shall also have a power supply input terminal

block accepting suitable power supply to be used for the output side circuitry of the hall sensors. This box is referred to as the 'HV box'.

Power supply to the two hall sensor boxes shall be provided through an isolated supply derived from 230 V, 50 Hz ac mains. Appropriate circuitry deriving this supply shall be provided in a powder coated metal box with suitable input and output terminations, such that the outputs can be wired to the HC and HV boxes. This box shall be called as 'HPS box'.

The HC, HV and HPS boxes shall be housed in a separate cabinet placed below the table. This cabinet would also house the ac and dc drives for the Electrical Machine work stations in the power electronics laboratory. The boxes shall also carry the label HC, HV and HPS respectively. The cabinet is more fully described in the section on Drives.

The measurement inputs and outputs from HC and HV boxes shall be terminated on the measurement area of the table. The measurement input points shall be terminated on banana plug sockets, two for each sensor. The banana sockets shall be rated for 10 A capacities. The measurement outputs shall be terminated on BNC connectors, one for each sensor. The input and outputs for each sensor shall be grouped together to allow easy identification, but spaced out properly to allow easy access for connection.

Two 3½ digit LED panel meters shall be provided on the panel to measure the current sensor outputs. The meter shall not have an independent current transducer, but will work from the hall sensor outputs. There shall be a selection mechanism to allow selection of the hall sensor outputs to the meter. The hall sensors together with the meter shall act as a system such that the meter reads the true rms value of the current in the power circuit. The meters shall accept the hall sensor signals through selector switches. One meter shall receive signals from two sensors, while the other meter shall receive signals from the other three sensors. The selector switches shall be guaranteed for at least 16000 operations.

A similar arrangement shall be provided for the voltage sensor outputs as well.

All terminals shall be red (+) and black (-) pairs for voltage connections and blue (current in) and black (current out) for current connections.

B. Power Measurement

QUANTITY : 2x2x12 Units for Single-Phase Power and 2x2x12 Units for Three-Phase Power

The cabinet housing the HC, HV and HPS boxes shall also house two three-phase power transducers and two single-phase power transducers. They shall be powered from the HPS box.

The input to these power transducers and the outputs shall be terminated on the measurement area of the workbench. The inputs shall be of banana socket type (10 A rating). The outputs, limited to ± 10 V, shall be terminated on BNC terminations. These outputs shall also be routed to suitable digital LED panel meters (3½ digit) so as to indicate the actual power. There shall be one meter for three-phase transducer outputs and one for

single-phase. Their inputs shall be selectable using a selector switch (one for three-phase, one for single-phase).

C. Speed Measurement

QUANTITY : 2x12Units

The measurement area shall also have a digital LED panel meter (3½ digit) to indicate the speed in rpm of the shaft from the pickups on the machine set. The panel meter shall directly accept pulses from the pickup and indicate speed.

All panel meters shall have an associated legend marking to identify the readout type

3.11) DRIVES (relevant for power electronics laboratory only)

The vendor shall supply drives for the Electrical Machine work stations in the power electronics laboratory. These drives shall be housed in a cabinet already referred to above in the section on current and voltage measurements. The size of the cabinet shall not exceed 700 mm (width) X 600 mm (height) X 550 mm (depth). The cabinet shall be made of MS and have a proper earth connection. All power metal boxes within shall also have a suitably designed earth connection point.

3.11.1) AC Drives

QUANTITY :10 Units

The specifications of the ac drive (meant to drive the induction motor in the machine set) unit are as follows. The vendor shall specify the time duration the machine can be operated on full load under inverter supply at various speeds.

Input	:	415V±10%,50±5%Hz,3 wire
Output	:	0-415V, Variable Frequency (range: 0 to 50Hz)
Rated Power	:	1kW
Control Type	:	V/f and Vector Control
Input Section	:	Diode Bridge
Output Section	:	Four Quadrant Inverter
Braking	:	Dynamic Braking Resistor Should be provided
Speed Feedback	:	DC Voltage
Speed Reference	:	Adjustable in control panel (10V for maximum speed)
Controller Gains	:	Adjustable by the user

The drive shall also have facility to be run as a multiple motor and drive system accepting reference command on a common communication bus for future use. The drive shall have the capability to use all popular communication protocols – CANBUS / PROFIBUS / Devicenet / MODBUS

3.11.2) DC DRIVES

QUANTITY : 10 Units

The specifications of the dc drive (meant to drive the dc motor in the machine set) unit are as follows. The vendor shall specify the time duration the machine can be operated on full load under drive operation at various speeds.

Input Voltage	:	415V±10%, 50±5%Hz,3 wire
Output Voltage	:	0 to 220V
Output Power	:	1.1kW
Drive Type	:	Dual Converter
Braking	:	Regenerative
Speed Feedback	:	DC Voltage
Speed Reference	:	Adjustable in control panel (10V for maximum speed)
Controller Gains	:	Adjustable by the user

The drive shall also have facility to be run as a multiple motor and drive system accepting reference command on a common communication bus for future use. The drive shall have the capability to use all popular communication protocols – CANBUS / PROFIBUS / Devicenet / MODBUS.

3.12) CABLES; Cables of 10 A capacity should be supplied which must be terminated on both ends with banana plugs of 10 A capacity. The number and length of these cables shall be such that all tests mentioned in the section 5 shall be feasible, with 10% more as spare (on a per CMB basis). In addition, signal cables terminated with BNC connectors on either side shall be supplied. These will be 20 in number per CMB.

4) Scope of the Institute

The Institute specifies the following as the acceptable brands.

Acceptable Brands

1. The acceptable brands for the electrical machines are:

- SIEMENS, ABB, GENERAL ELECTRIC CO, BALDOR, RELIANCE, KIRLOSKAR ELECTRIC CO, INTEGRATED ELECTRIC CO, TERCO, CROMPTON GREAVES

2. The acceptable brands for the electric drives are: SIEMENS, ABB, GENERAL ELECTRIC CO, ROCKWELL AUTOMATION

3. For the purpose of compatibility and stocking of spares, the similar machines, drives/components in all workstations shall be of same make and model.

For example, all dc machines (with same rating) in all the workstations shall be of same make and model.

Similarly all the three phase Induction machines (with same rating) in all the workstations shall be of same make and model.

5) Inspection and Acceptance

The bidder who meets all the conditions and approved by the selection committee shall setup one complete and functional prototype unit (in NITT premises) as per the specifications herein within three weeks of intimation.

The vendor shall arrange for inspection of this prototype at their premises by an NIT –T team. The vendor must give the test reports of all the machines in the unit confirming the specification. In addition, the following tests shall be done in the presence of the NIT-T team to verify the working of the overall setup. The necessary set up for experimentation and observations shall be in the scope of the vendor.

1. No-load, blocked-rotor and load tests on the induction machine.
2. DC motor speed-torque characteristics, DC generator characteristics, Hopkinson's test and Swinburne's test.
3. Synchronous machine OC/SC test, synchronization of the machine to ac grid by dark-lamp method, and determination of V-curves as generator and motor, determination of X_d and X_q of the machine.
4. Operation of the dc drive to demonstrate four quadrant operation, with speed control.
5. Operation of the ac drive to demonstrate speed control in all the modes with braking.
6. Operation of ac and dc drives in closed loop control with speed reference given as analog voltage.
7. Reports of all the above tests shall be submitted to NIT-Tiruchirappalli.

On successful completion of these tests, the prototype shall be type-approved.

The vendor shall, for every setup, conduct tests to satisfy themselves of proper operation and certify the completion. Final acceptance of all units upon delivery and installation will be upon successful completion of all the above mentioned tests by NIT-T staff in the laboratory.

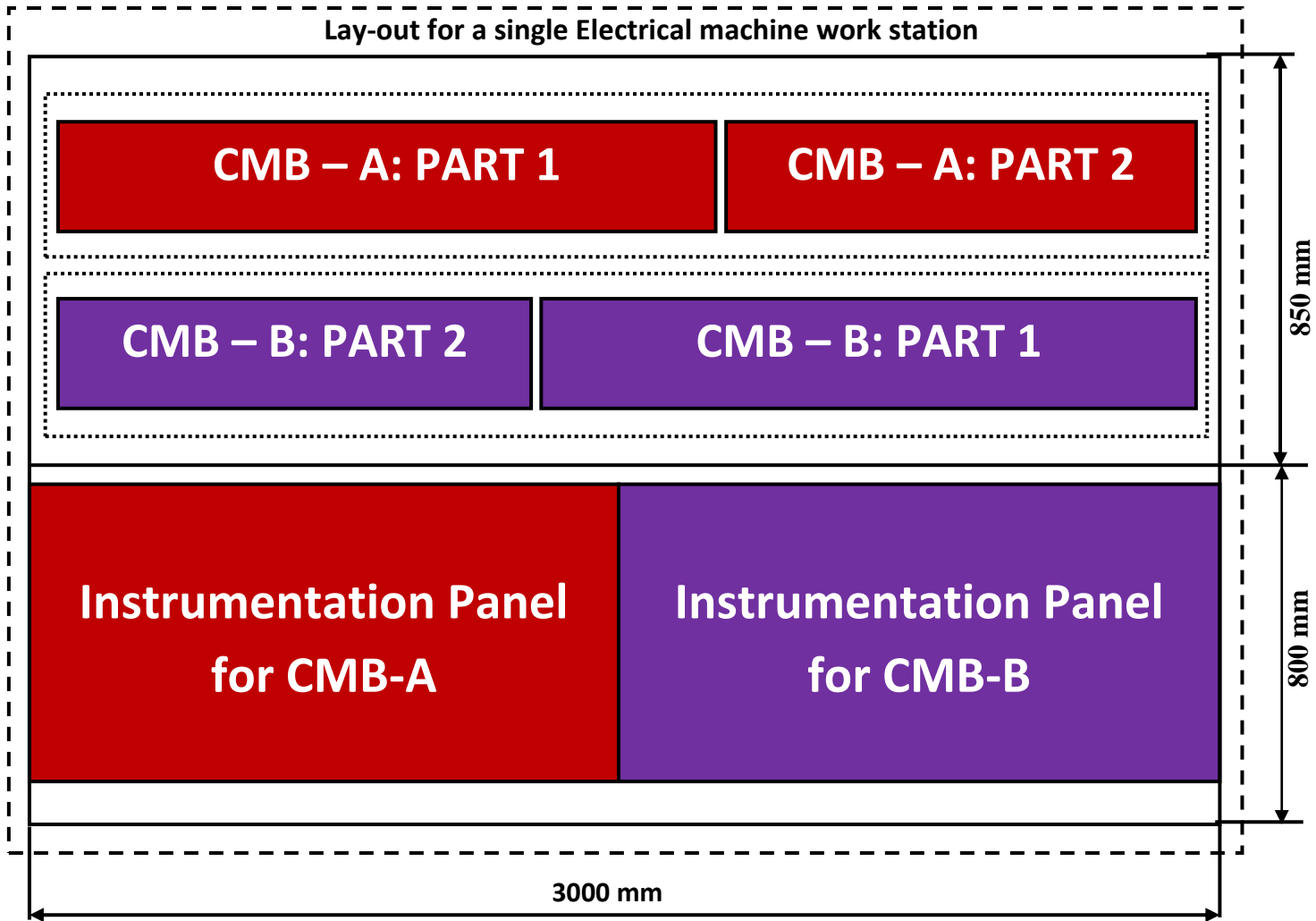

Fig.1. Lay-out for a single Electrical machine work station for Electrical Machines laboratory

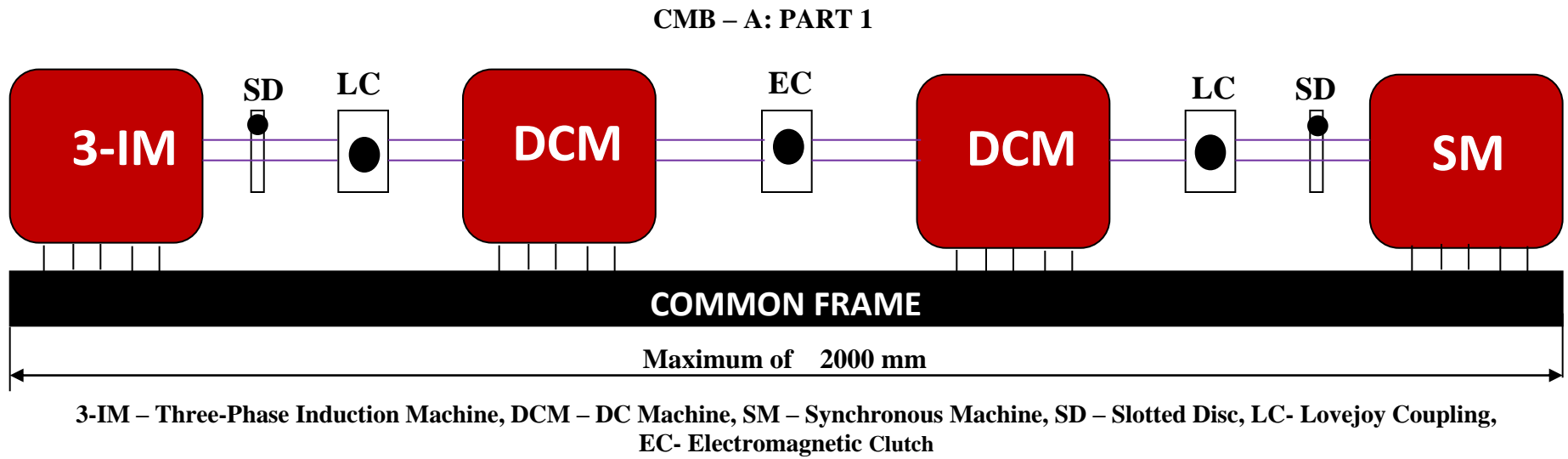

Fig.2. Lay-out for Composite machine Bench – A Part 1

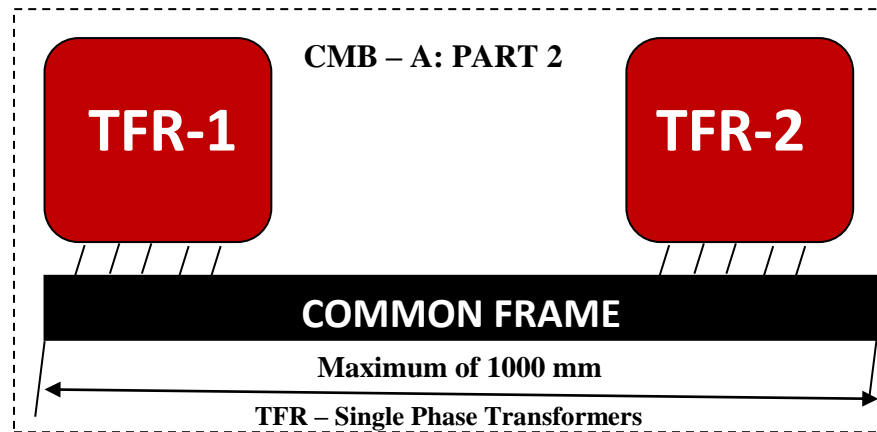

Fig.3. Lay-out for Composite machine Bench – A Part 2

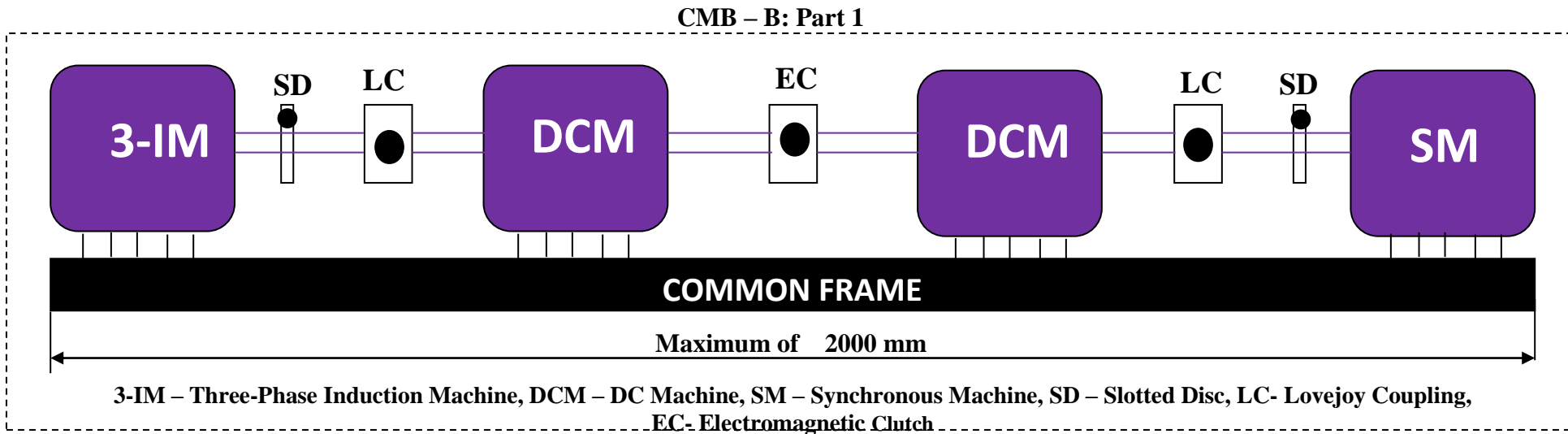

Fig.4. Lay-out for Composite machine Bench – B Part 1

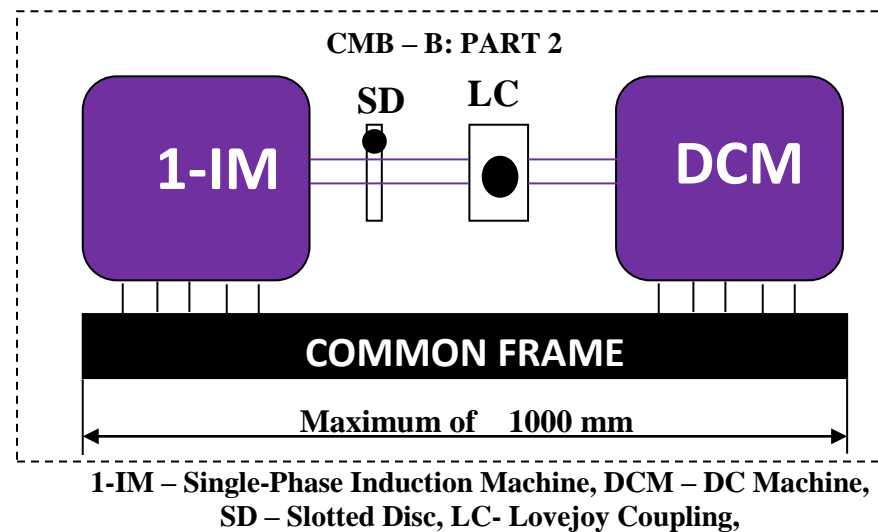

Fig.5. Lay-out for Composite machine Bench – B: Part 2

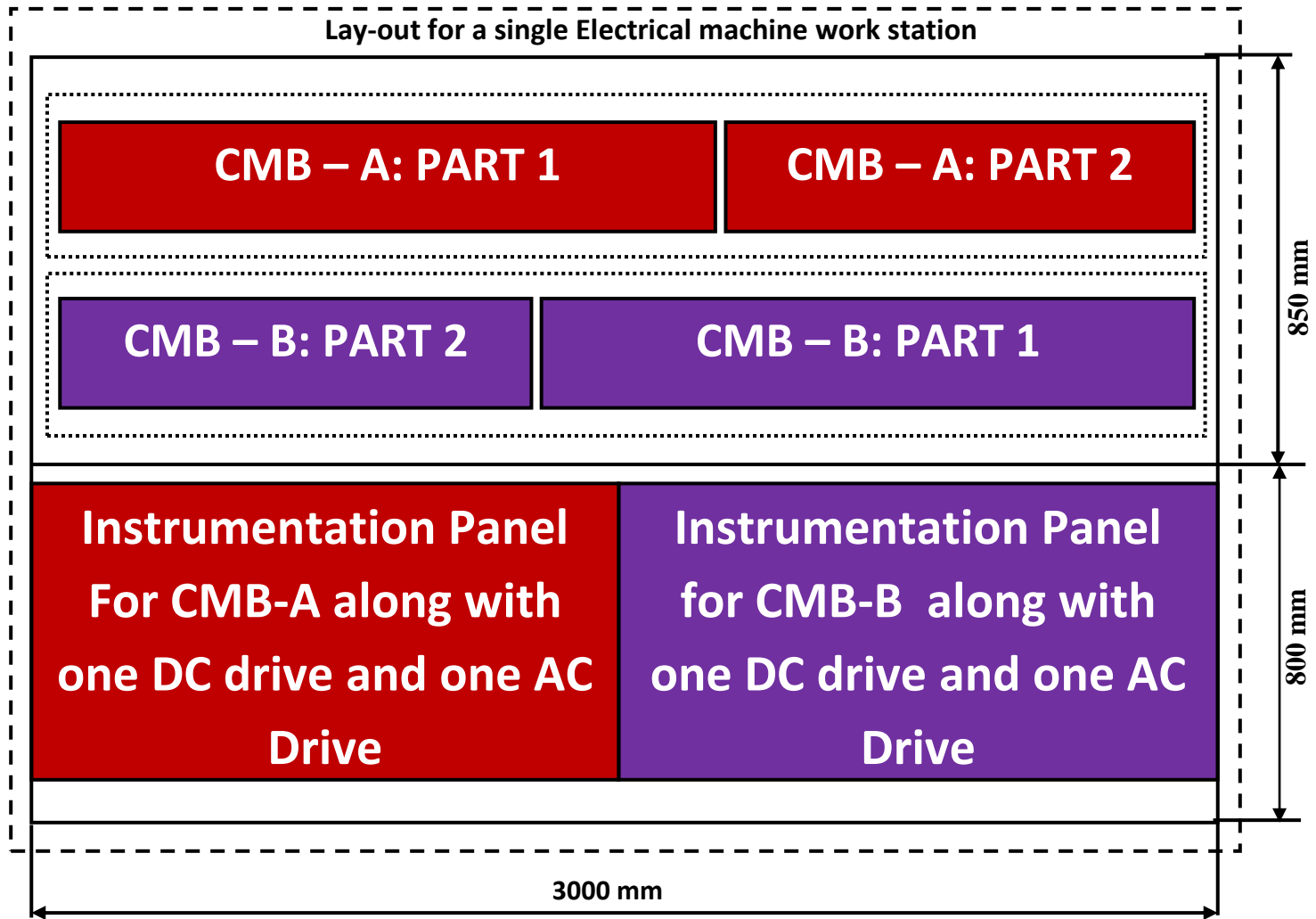

Fig.6. Lay-out for a single Electrical machine work station for Power Electronics Laboratory

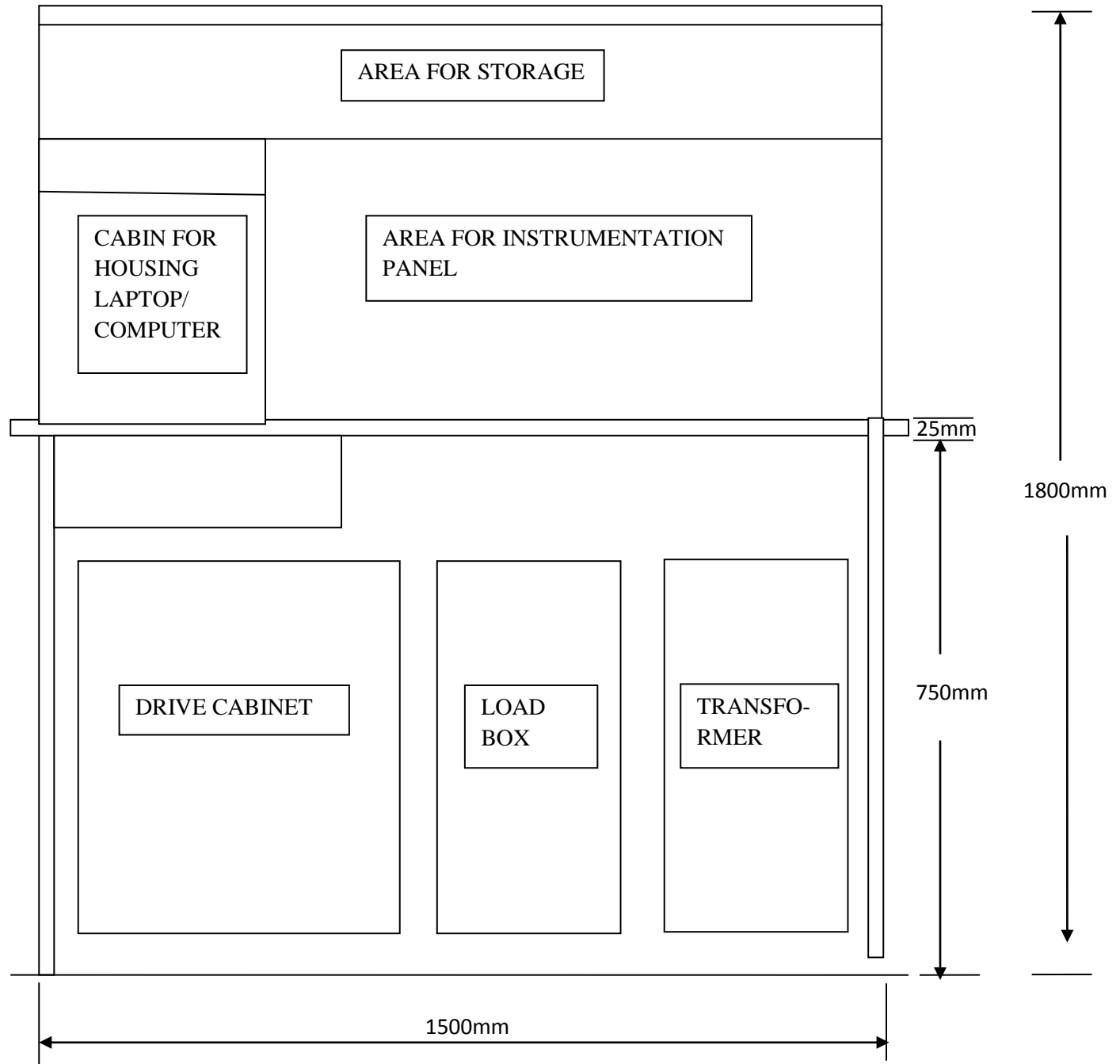

Fig.7 Layout of the wooden worktable-front view

CHAPTER 8: FORMAT FOR SUBMISSION OF TECHNICAL BID

	Item/ Requirement from the Bidder	Bidders Response should be definite, complete and legible. Use separate sheet wherever necessary.		
1	Particulars of remittance of EMD: Specify (a) DD Number/ Bank Guarantee (b) Amount (c) Name of Issuing Banker In the case of EMD in the form of Bank Guarantee, specify the name of the issuing banker and the Validity period.			
2	Particulars of remittance of Cost of Tender Document. Specify (a) DD Number (b) Amount (c) Name of Issuing Banker			
3	Name and Complete Postal address of the Applicant or Bidder Firm/ Company with phone/ Fax/ Mobile number			
4	Website Address, if any, of the Bidder firm / company			
5	Legal status / Constitution of the Bidder in INDIA : (a) Sole Proprietor (b) Partnership (c) Private Limited Company (d) Public Limited Company (e) others Please attach self-attested documentary proof			
6	Registration particulars for Establishment / Incorporation of the Bidder as Partnership firm/Private Limited Company/ Public limited Company etc., (Attach self-attested documentary evidence)	Authority	Registration Number	Place, date and Year of registration/ incorporation
7	Year of Commencement of Business			
8	Location of the Registered / Main Office			
9	Classification of the bidder (a) Manufacturer or (b) Authorized Agent or (c) Authorized Dealer or d) Stockiest or (e) others, specify			
10	Whether “ SCHEDULE OF DEPARTURE ” from technical Specifications furnished by the bidder along with the Technical Bid?	Note: This has to be furnished in the Format prescribed in ANNEXURE 1 to the Technical Bid.		
11	If the bidder is an authorized dealer/ distributor/ stockiest, whether authorization letter from the Original Equipment Manufacturer is attached? (Note: Without this authorization letter, the bid will not be considered)	This should be furnished in the format prescribed in the ANNEXURE 2 to the Technical Bid.		

12	Nature of the Business of the Bidder			
13	In the case of Manufacturer, copy of the Registration Certificate. Location of the Manufacturing Plant with address.			
14	(a) Name, (b) address ,(c) designation, (d) phone & cell number and (e) E mail ID of the CONTACT PERSON of the applicant/ bidder			
15	Name and address of your banker			
16	Copy of Income Tax Permanent Account Number (PAN Number) (Please Attach self-attested Xerox copy)			
17	Annual Turnover during the Last three financial years 2011-12, 2012-13 and 2013-14 (Profit and Loss Account and Balance sheet duly audited and certified by a Chartered Accountant and Income Tax Return Acknowledgement i.e., ITR for the last three years MUST be attached)			
18	Information from Balance Sheet			
	Particulars	2011-12	2012-13	2013-14
	Total Assets			
	Total Liabilities			
	Current Assets			
	Current Liabilities			
	Information from Income Statement			
	Profit Before Taxes			
19	Latest Income Tax Assessment Completion Certificate/ Income tax clearance certificate (In the event of assessment of the recent previous year having not been completed the certificate of the latest assessment completed may be enclosed)			
20	VAT/ TIN number (Self attested xerox to be attached)			
21	Central Sales Tax (CST) Number (Self attested Xerox copy to be attached)			
22	Service Tax Registration Number, (Self attested Xerox copy to be attached)			
23	Details of ISO or any other certification, obtained by the Bidder (attach documentary proof)			

24	Details of similar job/ project/ system executed during the preceding THREE YEARS, as on the date of signing the bid (Attach complete set of supporting documents and use separate sheet wherever necessary/ required) This is list of present and Past clients.	This information should be furnished in the format prescribed ANNEXURE 3 to the Technical bid.
25	Detailed list of supply, installation and commissioning of SIMILAR Project/ System / Machines/ Equipment SUPPLIED to Indian Institute of Technologies / National Institute of Technologies / State or Central Universities during the last three (3) Financial Years: (Attach complete set of supporting documents and use separate sheet wherever required)	This information should be furnished in the format prescribed ANNEXURE 4 to the Technical bid.
26	Whether “PRICE REASONABILITY CERTIFICATE” furnished along with the Technical Bid?	Note: This has to be furnished in the Format prescribed in ANNEXURE 5 to the Technical Bid.
27	<ol style="list-style-type: none"> 1. Details of Maintenance and Service Centre Facilities available in Tamil Nadu and total number of engineers available. 2. Name of the contact person and contact details. 3. What type of maintenance support does your company provide for the spares 4. What type of testing equipment available with your testing center? 5. What are your conditions for up gradation of equipment system after the warranty period? 6. In case of breakdown of equipment what will be the mean downtime? And state whether standby systems will be provided? 	
28	If the bidder even been blacklisted by any Government/ PSU/ University/ Autonomous bodies? Please give details and reasons thereof. If black listed and Revoked give details of the same.	This information should be furnished in the format prescribed ANNEXURE 6 to the Technical bid.
29	Specify whether there are any issues/ Litigations/ Court cases, if any, against your firm/ company y connected with Layout Design, supply, installation and commissioning of the Electrical Machine work stations for the Electrical Machines Laboratory and Power Electronics Laboratory	

Authorized signatory of Bidder with Seal

Name.....

Designation.....

=====

ANNEXURE 1 TO FORMAT FOR TECHNICAL BID
TECHNICAL SPECIFICATION COMPLIANCE SHEET

Important Note: Where there is no deviation, the statement should be returned duly signed with an endorsement indicating "NO DEVIATIONS". Furnishing of wrong statement may lead to debar.

Technical Specifications as per tender (POINT WISE)	Compliance to quoted model	Compliance to alternate model	Deviations

Note: Where there are no deviation, the statement should be returned duly signed with an endorsement indicating "No Deviations"

Date:

Place:

Authorized signatory of Bidder with Seal

Name.....

Designation.....

ANNEXURE 2 TO FORMAT FOR TECHNICAL BID

FORMAT FOR MANUFACTURER'S AUTHORISATION LETTER TO AGENT (on letter head)

Ref. No.

Date:

To

The Director, National Institute of Technology
 Thuvakkudi, Tiruchirappalli- 620 015, Tamil Nadu, India

Sub: Authorization Letter.

Dear Sir,

We, _____, who are established and reputed manufacturers of _____, having factory at _____, hereby authorize M/s. _____ (name & address of Indian Distributor/ Agent/ Dealer/ Channel Partner) to bid, negotiate and conclude the order with you for the above goods manufactured by us.

(2) We shall remain responsible for the tender / contract / agreement negotiated by the said M/s. _____, jointly and severally.

(3) We ensure that we would also support / facilitate the M/s. _____ on regular basis with technology / product updates for up-gradation /maintain /repairing / servicing of the supplied goods manufactured by us, during the warranty period.

(4) In case duties of the Indian agent / distributor are changed or agent / distributor is changed it shall be obligatory on us to automatically transfer all the duties and obligations to the new Indian Agent failing which we will ipso-facto become liable for all acts of commission or omission on the part of new Indian Agent / distributor.

Yours faithfully,

[Name & Signature &Seal]

For and on behalf of M/s. _____[Name of manufacturer]

Note: This letter of authorization should be on the letterhead of the manufacturing concern and should be signed by a person competent and having the power of attorney to bind the manufacturer.

ANNEXURE 3 TO FORMAT FOR TECHNICAL BID

Type of system/ items/ goods/ equipment supplied, installed and commissioned during the preceding 3 years, as on the date of signing the bid. This is list of present and past clients.

Sl. No	Name of the System/ Project/ item/ goods/ equipment supplied/ installed and commissioned	Capacity or Model	Name of the Manufacturers and Country of Origin	Total Number supplied, installed and commissioned in India	Number of orders in Hand
1.					
2.					
3.					
4.					
5.					

Signature and seal of the Bidder

ANNEXURE 4 TO FORMAT FOR TECHNICAL BID

Details of Design, Supply, Installation, Commissioning or execution of Similar Project/ System/ Job/ equipment in Indian Institute/s of Technology, National Institute/s of Technology, Central/ State Universities or any other Higher Technical Institutions under Government of India during the preceding THREE years, as on the date of signing this bid.

Sl. No	Purchase Order placed by (full address of the Purchaser)	Purchase Order Number and date	Description and quantity of the similar system/ project/ job executed	Total Value of the Purchase Order	Date of completion of installation and commissioning as per the contract & Date of actual commissioning	Remarks indicating reasons for delay, if any	Has the item has been supplied/ installed satisfactorily ? (Attach a certificate from the purchaser)	Contact person along with telephone number, mail id & address of the Purchase Initiator in IIT/ NIT etc.,
1								
2								
3								
4								
5								

Signature and Seal of the Bidder

**ANNEXURE 5 TO FORMAT FOR TECHNICAL BID
PRICE REASONABILITY CERTIFICATE**

(To be furnished under the letter head of the bidder)

It is certified that the RATE quoted against the NITT's tender numberdated _____ for the design, supply, installation and commissioning of, is not more than the rates charged to other NIT's / IIT's / Government Organizations / Research Laboratories / Defense establishments, for similar supplies made by our firm, in the recent past. If at any stage, it has been found that the quoted rate to NITT is higher than the rates charged to above mentioned Institutions, then in such a situation / condition, NITT shall have the right to take legal action against us, for recovery of excess rates.

Yours faithfully,
Authorized signatory of Bidder with Seal

ANNEXURE 6 TO FORMAT FOR TECHNICAL BID

AFFIDAVIT REGARDING BLACK LISTING / NON BLACK LISTING FROM TAKING PART IN GOVT. TENDER (To be executed in Rs.10/ Stamp paper and attested by Public Notary/ Executive Magistrate by the Bidder)

I / We Proprietor / Partner (s) / Directors of M/s.hereby declare that the firm/ company namely M/s.has not been blacklisted or debarred in the past by any Government Institution/ organization from taking part in Government tender. Or I / We Proprietor/ Partner(s)/ Director (s) of M/s.hereby declare that the firm / Company namelywas blacklisted or debarred by any Government Institution / Department from taking part in Government tenders for a period of Years with effect from The period is over onand now the firm/ company is entitled to take part in Government tender/ contract will be rejected/ cancelled by NIT, Tiruchy and EMD/ SD shall be forfeited. In addition to the above, NIT, Tiruchy will not be responsible to pay the bills for any completed / partially completed work.

Signature
Name.....
Capacity in which assigned
Name and address of the firm

Signature of the Bidder with seal

=====

ANNEXURE 7 TO THE TECHNICAL BID

CERTIFICATE OF GUARANTEE/WARRANTY (ON LETTER HEAD OF THE BIDDER)

I / We certify that the guarantee/warranty shall be given for a period of FIVE YEARS starting from the date of the satisfactory installation, commissioning and handing over of the equipment/ system/ project and the work completed under the contract.

During the guarantee / warranty period, I / We shall provide the “after sale service” and the replacement of defective /or any part(s) of the equipment or rectification of defects of work of the equipment will be FREE OF COST.

THE REPLACEMENT OF THE PARTS SHALL BE ARRANGED BY US, AT OUR OWN COST AND RESPONSIBILITY.

We undertake that the above guarantee /warranty shall begin only from the date of handing over of the equipment/ system/ project.

During the warranty period, we shall provide at least **6 preventive maintenance** visits per year. During the guarantee/warranty period, we will be responsible to maintain the

equipment/ system/ project including all the accessories in the satisfactory faultless working conditions for a period 347 days (i.e.95% uptime) in a block of 365 days.

All complaints will be attended by us within 4 working days of receipt of the complaint in our office. In case there is delay of more than 4 days in attending the complaint from our side then the Institute can count the number of days in excess of the permissible response time in the downtime. The above said response time of 4 days for attending to a complaint by us will not be counted in the downtime.

Penalty: We shall pay a penalty equivalent to 1% of the order value of the equipment for every week or part therefore delay in rectifying the defect. No deduction or advantage of any kind on account of Sundays, half days or Public/ Govt. holidays observed by the Institute shall be allowed from the total down time permissible as defined above. The right to accept the reason(s) for delay and consider reduction or waive off the penalty for the same shall be at the sole discretion of the Institute.

I / We shall try to repair the equipment/ project/ system at Institute premises. However, in case it is not possible to repair the equipment at Institute premises, we will take out the equipment to our site on our own expenses. We shall take the entire responsibility for the safe custody and transportation of the equipment taken out for repairs till the equipment is rehabilitated to the Institute after repair. If any loss of equipment occurred during our custody, we will restore it / compensate to Institute for such losses.

I / We guarantee that in case we fail to carry out the maintenance work within the stipulated period, the Institute reserves the right to get the maintenance work carried out at our risk, cost and responsibility after informing us.

All the expenses including excess payment for repairs / maintenance shall be adjusted against the Performance Bank Guarantee. In case the expenses exceed the amount of the Performance Bank Guarantee, the same shall be recoverable from us with / without interest in accordance with the circumstances.

I / We undertake to perform calibration after every major repair / breakdown / taking the equipment out for repair from the Institute premises.

I / We guarantee that we will supply spare parts, FREE OF COST, during the warranty period.

I / We guarantee to the effect that before going out of production of the spare parts, we will give the adequate advance notice to Institute so that Institute may undertake to procure the balance of the life time requirements of the spare parts.

Authorized signatory of the company with seal

ANNEXURE 8 TO THE TECHNICAL BID
CERTIFICATE AND DECLARATION BY THE BIDDER
To be furnished under the letter head of the bidder

1. It is hereby declared that I/ we the undersigned, have read and examined all the terms and conditions etc., of the tender document for which I / We have signed and submitted the tender.
2. It is also certified that all the terms and conditions of the tender are fully acceptable to me/ us and I/ we will abide by the conditions.
3. I / We hereby declare that our proposal is made in good faith, without collusion and fraud. No forged/ tamper documents are produced with tender form for gaining unlawful advantage. We understand that NIT, Tiruchy is authorized to make any enquiry to establish the facts claimed by us and obtain confidential reports from our clients.
4. In case if it is established that any information provided by us is false/ misleading or in the circumstances where it is found that we have made any wrong claims, we are liable to forfeiture of EMD and / or any penal action and other damages including withdrawal of all work/ purchase orders being executed by us. Further, NIT, Tiruchy is authorized to blacklist our firm/ agency/ company and debar us in participating in any tender/ bid in future.
5. I/ we assure that I / We will not be outsourcing any work specified in the tender document, to any other firm.
6. Neither I/ We, nor anybody on my/ our behalf will indulge in any corrupt activities/ practices in my / our dealing with the NIT, Tiruchy.
7. I/ We further certify that I / We possess all the statutory / non statutory registrations, permissions, approvals, etc., from the competent authority for providing the requisite goods/ services.
8. We understand that NIT, Tiruchy is not bound to accept the lowest or any bid that NITT may receive.
9. I / We hereby declare that this tender on acceptance communicated by NITT shall constitute a valid and binding contract between us. I/We certify that no addition/modification/alteration has been made in the Original Tender Document. If at any stage addition /modification /alteration are noticed in the Original Document, NIT, TIRUCHI can reject the tender and/or cancel the contract.
10. I / We certify that the Technical Bid, ANNEXURE to the Technical Bid and the Price Bid submitted by us are duly page numbered, signed and stamped.

Signature, Seal of the bidder with date
Name.....
Designation.....

**Annexure 9: CHECK LIST AND IMPORTANT DATES FOR BIDDERS
(To be enclosed with the Technical Bid)**

No	Particulars	Compliance by the Bidder
A. Matters relating to EMD amount and Cost of Tender Document		
1	Whether a separate Demand Draft for EMD (Rupees 6 lakh) and another Demand Draft for Cost of Tender Document (Rs. 1,000/-) has been submitted in a SEPARATE ENVELOPE ?	
2	In respect of Bidders who are seeking exemption from EMD amount and Cost of Tender Document, whether a registration certificate with NSIC has been furnished? What is the validity period for the certificate? Does the certificate hold good for materials/ equipment/ job tendered in our notice inviting tender?	
B. Matters relating to Technical Bid submission		
1	Whether Technical Bid and all the NINE ANNEXURES to the Technical Bid are serially numbered and over writing or erasures, if any, duly been initialed & endorsed? Whether Technical Bid along with NINE ANNEXURES are kept inside a SEPARATE ENVELOPE and the said envelope is super scribed as per the instructions given?	
2	In the case of submission of bid by authorized agent/ distributor/ dealer whether authorization letter from the original Equipment Manufacturer is submitted in the Format Prescribed in Annexure 1 to the technical bid?	
3	In the case of Manufacturer, has the Registration Certificate has been enclosed?	
4	In the technical bid, Whether Technical Specification for the each of the item quoted is attached? Whether Catalog/ Leaflet/ Standard technical literature on each of the items offered has been furnished?	
5	Whether Standard Warranty for FIVE Years has been quoted along with the basic price? Whether duly filled and signed Warranty Certificate attached in the prescribed format?	
6	Whether list of institutions / organizations where the quoted model of equipment/system/ project/ instrument has been supplied by the bidder is attached in the Prescribed Format? If supplied identical or similar system/ equipment / project to other NITs/ IITs/ IIMs/ Central, State Universities/ Research Institutions etc., whether the details of such supplies has been enclosed together with the PRICES EVENTUALLY OR FINALLY PAID?	

C. Matters relating to Price Bid submission		
1	Whether Price Bid for Indigenous item submitted in the prescribed format in Chapter 9? In the case of import, whether Price Bid for the imported item has been submitted in the Format prescribed in Chapter 10?	
2	Whether split up rates for each of the sub units are quoted?	
3	Whether the Price bid has been submitted under the Letter Head of the bidding firm/ company/ agency?	
4	Whether the Price Bid has been kept inside a SEPARATE ENVELOPE and the said envelope is super scribed as per the instructions given	
D. Matters relating to Signing, Sealing and Marking of Bids		
1	Whether all the pages of the tender document (technical bid, its enclosures and Price bid) duly signed and stamped by the Authorized signatory?	
2	Whether the THREE SEPARATE ENVELOPES containing (a) Cost of Tender Document + EMD (b) Technical Bid and (c) Price Bid are placed and wrapped in a Larger Size Outer Envelope AND ALL THE FOUR ENVELOPS are sealed and super scribed as instructed?	
3	Whether the following documents have been enclosed with the Technical Bid: 1. Audited and certified Annual Accounts, Income Tax Return and latest assessment orders, clearance certificate. 2. PAN/ VAT/ Service Tax Registration certificates 3. Whether duly filled in and signed technical compliance sheet attached (deviation from the technical specification)?	
4	Important dates	
	Tender Notification date	27.8.2014
	Pre bid conference date and time:	Monday 8 th September 2014
	Last date for submission of tender.	Monday 22 nd September 2014 up to 3 P.M
	Date of opening of Technical Bid.	Monday 22 nd September 2014 at 3.30 P.M

Signature, Seal of the bidder with date

Name.....

Designation.....

CHAPTER 9: PRICE BID FORMAT FOR INDIGENOUS PURCHASES

Tender No. & Date:

Name of the Bidder:

S. No.	Description of the item to be procured	Unit	Quantity	Basic Price in Rupees (Excluding all taxes and duties)	Excise Duty %	VAT/ CST in %	Service Tax in %	Total Amount in Rupees (Inclusive of all taxes and duties)
1	Supply Portion/ Main item (under the letter head of the bidder Individual Item wise break price shall be attached as an Annexure to this price bid)							
2	Additional / Optional items/ Accessories and Spares etc., (Individual Item wise break price shall be attached as an Annexure to this price bid)							
3	Installation and Commissioning Charges, if any							
4.	Packing and Forwarding Charges, if any							
5.	Freight and Transit Insurance Charges, if any							
6.	Any other charges, if any							
7.	TOTAL ALL INCLUSIVE PRICE (Supplied or Layout Design, Supplied, installed and commissioned at NITT on door delivery basis. (i.e., F.O.R. Destination Basis)							

Authorized signatory of Bidder with Seal

Note 1: NITT is eligible for exemption from Excise Duty and Concessional Customs Duty. Please refer the tender document. As regards Service tax, educational auxiliary services are exempt from Service Tax. As regards, sales tax NITT is not authorized to issue C or D forms for concessional VAT. However, it can issue end user certificate for claiming concessional VAT at the rate 5%. Note 2: Price bid Format should be supported with separate sheet duly typed and signed on the letter head of the bidding firm/ company indicating details i.e., different components/ parts/ units of the equipment (if any) with number, name and price of each part.

CHAPTER 10 : PRICE BID FORMAT FOR IMPORTS

Name of the Material/ Equipment

Name of the **Manufacturer**

MAKE of the Material/ Equipment

MODEL Number if any

Country of Origin:

S. NO	Item wise description of Goods/ Materials/ Equipment to be supplied from Foreign Country	Quantity	Rate Per Unit (In Foreign Currency)	Amount (in Foreign Currency)
1	Ex works price of the Main item/ material/ equipment			
2	Ex Works Price of the Additional/ Optional items, if any			
3	Ex works Price of Accessories and Spare Parts, if any			
	Total Ex Works Price (in Foreign Currency)			
4	Educational Discount, if any, offered on the Ex-Works price			
5.	Ex-Works Price after Discount (in Foreign Currency)			
6.	Add: Packing and Forwarding Charges if any from the Ex-works to loading Port/ Airport			
7.	Total FOB Price (in Foreign Currency)			
8.	Add: Air Freight, Insurance and Handling Charges upto Chennai Airport			
9.	Total CIF Value (Up to Chennai) or CIP Value (Up to Chennai) in Foreign Currency			
10.	TOTAL ALL INCLUSIVE TOTAL PRICE PAYABLE BY NITT IN FOREIGN CURRENCY			

Authorized signatory of Bidder with Seal

Note 1: NITT is eligible for exemption from Excise Duty and Concessional Customs Duty. Please refer the tender document. As regards Service tax, educational auxiliary services are exempt from Service Tax. As regards, sales tax NITT is not authorized to issue C or D forms for concessional VAT. However, it can issue end user certificate for claiming concessional TN VAT is 5%. Note 2: Price bid Format should be supported with separate sheet duly typed and signed on the letter head of the bidding firm/ company indicating details i.e., different components/ parts/ units of the equipment (if any) with number, name and price of each part.